



imove^c



VERSION 05 | 2013

PAPE+ROHDE
b ü r o e i n r i c h t u n g e n

Inhaltsverzeichnis	Kapitel	Contents	Chapter
Oberflächen - Farben	01.01 - 01.06	surfaces - colours	01.01 - 01.06
Erläuterungen	02.01 - 02.03	explanations	02.01 - 02.02
Arbeitstische	03.01 - 03.07	work stations	03.01 - 03.07
Tische mit zwei Fußschienen		desks with 2 foot bars	
Tische für Korpusunterbau		desks for lowboards, pedestals	
Tische, angewinkelt		angled work stations	
Tische, Eckform		corner work stations	
Tische, Freiform		free-form work stations	
Unterbauten	04.01 - 04.03	carcass	04.01 - 04.03
Lowboards		lowboards	
Technikcontainer		pedestals for files and hardware	
Ankettische	05.01 - 05.03	add-on desks	05.01 - 05.03
Ankettung rechteckig		90 deg. connection	
Ankettische, Besprechung		add-on conference desks	
Besprechungstische	06.01 - 06.03	conference desks	06.01 - 06.03
Kabelmanagement	07.01 - 07.02	cable management	07.01 - 07.02
Zubehör	08.01 - 08.02	accessories	08.01 - 08.02
Monitorarme		monitor arms	
CPU-Halter		CPU stand	
Rückwände		modesty panels	
Aufsatzwände		table top screens	
Schiebetür-Anstellelemente	09.01	side cupboard units with sliding door	09.01

Auflage 05

gültig ab 01. August 2013
geringe Konstruktionsänderungen vorbehalten
alle Maßangaben in Zentimeter

Zertifizierungen

Das Unternehmen ist nach DIN EN ISO 9001:2008 zertifiziert.
GS-Zeichen für iMOVE^C-Arbeitsplatzsystem



Edition 05

recommended retail price
without VAT, prices in EURO,
valid from August 1st, 2013
slight constructional alterations subject to change
all dimensions are indicated in cm

Certificates

the company is certified according to DIN EN ISO 9001:2008
iMOVE^C office system has received the GS certificate



Artikelbezeichnung und Farbkennung

Zur eindeutigen Bestimmung eines Artikels ist die Angabe

- der Artikelbezeichnung und
- der Farbkennung erforderlich.

In Artikelbezeichnungen, die Varianten enthalten, müssen eine oder mehrere Angaben, z. B. zu Oberfläche oder Plattennummer, eingesetzt werden. Die einzusetzenden Zeichen entsprechen der Anzahl der Sternchen (*). Optionen werden durch Ergänzungen zur Artikelbezeichnung gekennzeichnet. Zum Teil muss für die Optionen ein Aufpreis addiert werden.

Die Anzahl der notwendigen Farbangaben variiert von Artikel zu Artikel. Die Reihenfolge ist durch Nummerierung definiert.

IMC2TR1	-16	-H2	-SM	-FO3	055/076/049
rechteckig, 80 cm tief					
Breite: 160 cm					
Verstellart: Handverstellung					
Variante: Spanplatte, Melamin					
Option: Fußschienen Aluminium poliert					
Notwendige Farbangaben:					
1. Gestell: kristallweiß struktur					
2. Fußschienen: Aluminium poliert (Option)					
3. Platte: kristallweiß					

Article reference and colour code

For the exact article definition the following details are required:

- the article reference and
- the colour code

Articles which are available in different variants have to be completed with one or more details such as the surface or the desk number. The number of stars (*) shows the number of symbols which have to be indicated.

Options will be added to the article reference and the up-charge for some options has to be added to the basic article price.

The number of required colour codes is different for each article. The sequence is defined by the numbering.

IMC2TR1	-16	-H2	-SM	-FO3	055/076/049
rectangular, 80 cm deep					
width: 160 cm					
adjustment: by hand					
variant: chipboard, melamine					
option: foot bars: polished aluminium					
necessary colour detail:					
1. frame: crystal white structure					
2. foot bar: aluminium polished (option)					
3. top: crystal white					

Bei diesen Artikeln sind unbedingt Farbangaben bei der Bestellung notwendig:
Colours of the following articles must be indicated in the order:

Artikel	article	Farbcode / colour code
Arbeitsische	work stations	
- Gestell*	- frame*	- 021, 022, 023, 029, 055, 056, 068, 075 (Option -FO2)**
- Fußschienen*	- foot bars*	- 021, 022, 023, 029, 055, 068, 076 (Option -FO3)***
- Platte	- top	- 011, 024, 026, 041, 042, 049, 051, 052, 080, 081, 082, 111, 122, 131, 132, 141, 161, 171, 181, 191
Ankettische, Besprechungstische	add-on desks, conference desks	
- Gestell*	- frame*	- 021, 022, 023, 029, 055, 056, 068, 075 (Option -FO2)**
- Fußplatte*	- foot plate*	- 021, 022, 023, 029, 055, 068, 077 (Option -FO5)***
- Platte	- top	- 011, 024, 026, 041, 042, 049, 051, 052, 080, 081, 082, 111, 122, 131, 132, 141, 161, 171, 181, 191
Besprechungstische fahrbar	mobile conference desks	
- Gestell*	- frame*	- 021, 022, 023, 029, 055, 068
- Platte	- top	- 011, 024, 026, 041, 042, 049, 051, 052, 080, 081, 082, 111, 122, 131, 132, 141, 161, 171, 181, 191
Kabeldurchlass aus Kunststoff	cable outlet made of plastic	- 014, 044, 049
Kabeldurchlass aus Metall	cable outlet made of metal	- 057, 059
Lowboards	lowboards	
- Korpus	- carcass	- 011, 014, 024, 026, 041, 042, 049, 051, 052, 072, 080, 081, 082
- Front	- front	- 011, 014, 024, 026, 041, 042, 049, 051, 052, 070, 071, 072, 080, 081, 082, 111, 122, 131, 132, 141, 161, 171, 181, 191
- Abdeckplatte Echtholz (Option)	- top real wood (option)	- 111, 122, 131, 132, 141, 161, 171, 181, 191
- Kabelkette	- cable chain	- 044, 049
- Kabelkettendurchlass	- cable chain outlet	- 021, 022, 023, 029, 055, 056, 068
Technikcontainer	pedestals	
- Korpus	- carcass	- 011, 014, 024, 026, 041, 042, 049, 051, 052, 072, 080, 081, 082
- Blenden/Abdeckplatte	- blinds/top	- 011, 014, 024, 026, 041, 042, 049, 051, 052, 072, 080, 081, 082, 070 (Option -FO1) , 071 (Option -FO1), 111, 122, 131, 132, 141, 161, 171, 181, 191
- Kabelkette	- cable chain	- 044, 049
- Kabelkettendurchlass	- cable chain outlet	- 021, 022, 023, 029, 055, 056, 068
Kabelwanne*	cable tray*	- 021, 022, 023, 029, 055, 056, 068
Kabelkette mit Standfuß	cable chain with foot	
- Kabelkette	- cable chain	- 044, 049
- Standfuß*	- foot*	- 021, 022, 023, 029, 055, 056, 068
Kabelschlange	cable chain	- 014, 045
CPU-Halter*	CPU stand*	- 021, 022, 023, 029, 055, 056, 068
Rückwände	modesty panels	
- Metallteile*	- metal parts*	- 021, 022, 023, 029, 055, 056, 068
- Rückwand	- modesty panel	- transluzent / translucent
Aufsatzwände	table top screens	
- Stoffbezug	- fabric	- siehe Prospekt Oberflächen, see brochure surfaces
Anstellelemente	side cupboard units	
- Korpus	- carcass	- 011, 014, 024, 026, 041, 042, 049, 051, 052, 072, 080, 081, 082
- Abdeckplatte und Front	- top and front	- 011, 014, 024, 026, 041, 042, 049, 051, 052, 072, 080, 081, 082, 111, 122, 131, 132, 141, 161, 171, 181, 191
- Traversenrohre*	- cross bars*	- 021, 022, 023, 029, 055, 056, 068

Diese Artikel haben immer folgende Farbausführung: / These articles are available only with the following colours:

Artikel	article	Farbcode / colour code
Facheinteilung für Organisationschubfächer (Sideboard)	drawer partitions (sideboard)	silber metallic / silver metallic
Abdeckstopfen f. Organisationsbohrungen	cover for organisation holes	Edelstahl / stainless steel
Monitorarm	monitor arm	silber metallic / silver metallic
Zubehör für Aufsatzwände	accessories for table top screens	silber struktur / silver structure
Griff Form A / N / M	handle type A / N / M	Alu farblos eloxiert / clear anodised aluminium
Griff Form B	handle type B	Edelstahl / stainless steel
Griff Form G / I / K	handle type G / I / K	matt verchromt / matt chrome-plated
Griff J	handle type J	Alu farblos eloxiert und hochglanzchrom / clear anodised aluminium and mirror finish

Farbkürzel / colour codes

011	lichtgrau	light grey	070	orangerot	orange red
014	schwarz	black	071	apfelgrün	apple green
021	schwarz struktur	black structure	072	graphit	graphite
022	silber struktur	silver structure	075	Aluminium gebürstet farblos eloxiert	aluminium brushed clear anodised
023	lichtgrau struktur	light grey structure	076	Aluminium poliert	aluminium polished
024	Buche Dekor	beech decor	077	Stahl verchromt	chrome-plated steel
026	Ahorn Dekor	maple decor	080	Pflaume Dekor	plum decor
029	silber metallic	silver metallic	081	Kirschbaum Dekor	cherry tree decor
041	weißaluminium	aluminium white	082	Olive dunkel Dekor	olive wood decor
042	Weißbuche Dekor	light beech decor	111	Echtholz Buche	beech veneer
044	alugrau	aluminium grey	122	Echtholz Esche schwarz offenporig	ash tree open-pored veneer
049	kristallweiß	crystal white	131	Echtholz Ahorn europäisch	European maple veneer
051	Balearen Eiche Dekor	Balearic oak decor	132	Echtholz Ahorn kanadisch	Canadian maple veneer
052	Zebrano Dekor	zebrano decor	141	Echtholz Schweizer Birnbaum	Swiss pearwood veneer
055	kristallweiß struktur	crystal white structure	161	Echtholz Zebra	walnut veneer
056	helium	helium	171	Echtholz Zebrano	zebrano veneer
057	hochglanzchrom	mirror finish	181	Echtholz Eiche	oak veneer
059	matt verchromt	matt chrome-plated	191	Echtholz Kirschbaum	cherry veneer
068	graphit struktur	graphite structure			









* weitere RAL-Farben auf Anfrage erhältlich, ohne Aufpreis / additional RAL-colours available upon request, without up-charge

** Farbausführung 075 für Arbeitstische und Besprechungstische, höhenverstellbar (optional gegen Aufpreis -FO2):



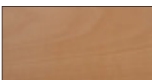





Säulenprofil Aluminium gebürstet farblos eloxiert 075, Gestell silber metallic 029
colour 075 for work stations and conference desks, height adjustable (option with up-charge -FO2):
columns aluminium brushed clear anodised 075, frame silver metallic 029

*** Farbausführung 076 (Option -FO3): Die Fußplatten der Ankett- und Besprechungstische werden dazu passend in 077 (-FO5) angeboten
colour 076 (option -FO3): The foot plates of add-on and conference desks are offered in matching colour 077 (-FO5)

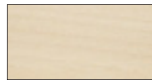

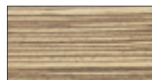
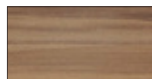

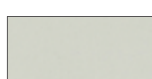
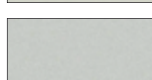

Platte (Furnier Echtholz)
Top (veneer surface real wood)

	111 Echtholz Buche beech veneer
	122 Echtholz Esche schwarz offenporig ash tree open-pored veneer
	131 Echtholz Ahorn europäisch European maple veneer
	132 Echtholz Ahorn kanadisch Canadian maple veneer
	141 Echtholz Schweizer Birnbaum Swiss pearwood veneer
	161 Echtholz Nussbaum walnut veneer
	171 Echtholz Zebrano zebrano veneer
	181 Echtholz Eiche oak veneer
	191 Echtholz Kirschbaum cherry veneer

Platte (Melamin)
Top (melamine surface)

	024 Buche Dekor beech decor
	026 Ahorn Dekor maple decor
	042 Weißbuche Dekor light beech decor
	051 Balearen Eiche Dekor Balearic oak decor
	052 Zebrano Dekor zebrano decor
	080 Pflaume Dekor plum decor
	081 Kirschbaum Dekor cherry tree decor
	082 Olive dunkel Dekor olive wood decor
	011 lichtgrau light grey
	041 weißaluminium aluminium white
	049 kristallweiß crystal white

Arbeitsstische: Gestell*
Work stations: frame*

	021 schwarz struktur black structure
	022 silber struktur silver structure
	023 lichtgrau struktur light grey structure
	029 silber metallic silver metallic
	055 kristallweiß struktur crystal white structure
	056 helium helium
	068 graphit struktur graphite structure

zusätzliche Option -FO2
additional option -FO2

	Säulen Aluminium gebürstet farblos eloxiert 075 Gestell silber metallic 029 columns aluminium brushed clear anodised 075 frame silver metallic 029
---	---

Farbabweichungen zu den Originaloberflächen sind möglich / Colours may vary from actual material

Arbeitstische: Fußschienen*
Work stations: foot bars*

	021 schwarz struktur black structure
	022 silber struktur silver structure
	023 lichtgrau struktur light grey structure
	029 silber metallic silver metallic
	055 kristallweiß struktur crystal white structure
	068 graphit struktur graphite structure

zusätzliche Option -FO3 für Fußschienen
additional option -FO3 for foot bars

	076 Aluminium poliert aluminium polished
---	--

Die Fußplatten der Annett- und Besprechungstische werden dazu passend in 077 Stahl verchromt (-FO5) angeboten
The foot plates of add-on and conference desks are offered in matching colour 077 (-FO5)

Ankett-/ Besprechungstische: Gestell*
Add-on desks, conference desks: frame*

	021 schwarz struktur black structure
	022 silber struktur silver structure
	023 lichtgrau struktur light grey structure
	029 silber metallic silver metallic
	055 kristallweiß struktur crystal white structure
	056 helium helium
	068 graphit struktur graphite structure

zusätzliche Option -FO2 für Besprechungstisch höhenverstellbar
additional option -FO2 for conference desks height adjustable

	075 Aluminium gebürstet farblos eloxiert aluminium brushed clear anodised
---	---

Ankett-/ Besprechungstische: Fußplatte*
Add-on desks, conference desks: foot plate*

	021 schwarz struktur black structure
	022 silber struktur silver structure
	023 lichtgrau struktur light grey structure
	029 silber metallic silver metallic
	055 kristallweiß struktur crystal white structure
	068 graphit struktur graphite structure

zusätzliche Option -FO5 für Fußplatten
additional option -FO5 for foot plates

	077 Stahl verchromt chrome-plated steel
--	---

passend zu Fußschienen der Arbeitstische 076 Aluminium poliert (-FO3)
matching with foot bars of work stations 076 aluminium polished (-FO3)

Besprechungstische fahrbar: Gestell*
Mobile conference desks: frame*

	021 schwarz struktur black structure
	022 silber struktur silver structure
	023 lichtgrau struktur light grey structure
	029 silber metallic silver metallic
	055 kristallweiß struktur crystal white structure
	068 graphit struktur graphite structure







Kabeldurchlass aus Metall
Cable outlet made of metal

	057 hochglanzchrom mirror finish
	059 matt verchromt matt chrome-plated









Kabeldurchlass aus Kunststoff
Cable outlet made of plastic

	014 schwarz black
	044 alugrau aluminium grey
	049 kristallweiß crystal white

Kabelwanne*; CPU-Halter*; Lowboard, Technikcontainer: Kabelkettendurchlass*
Cable tray*; CPU stand*; lowboard, pedestal: cable chain outlet*

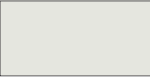
	021 schwarz struktur black structure		029 silber metallic silver metallic		068 graphit struktur graphite structure
	022 silber struktur silver structure		055 kristallweiß struktur crystal white structure		
	023 lichtgrau struktur light grey structure		056 helium helium		

Kabelkette mit Standfuß
Cable chain with foot

Standfuß* /foot*		Kabelkette /cable chain	
	021 schwarz struktur black structure		055 kristallweiß struktur crystal white structure
	022 silber struktur silver structure		056 helium helium
	023 lichtgrau struktur light grey structure		068 graphit struktur graphite structure
	029 silber metallic silver metallic		044 alugrau aluminium grey
			049 kristallweiß crystal white

Farbabweichungen zu den Originaloberflächen sind möglich / Colours may vary from actual material

Kabelschlange
Cable chain



Lowboard, Technikcontainer: Kabelkette
Lowboard, pedestal: cable chain



Lowboard: Korpus, Front; Technikcontainer: Korpus, Blenden/Abdeckplatte;
Anstallelement: Korpus, Front/Abdeckplatte (Melamin)
Lowboard: carcass, front; pedestal: carcass, blinds/top;
side cupboard unit: carcass, front/top (melamine surface)

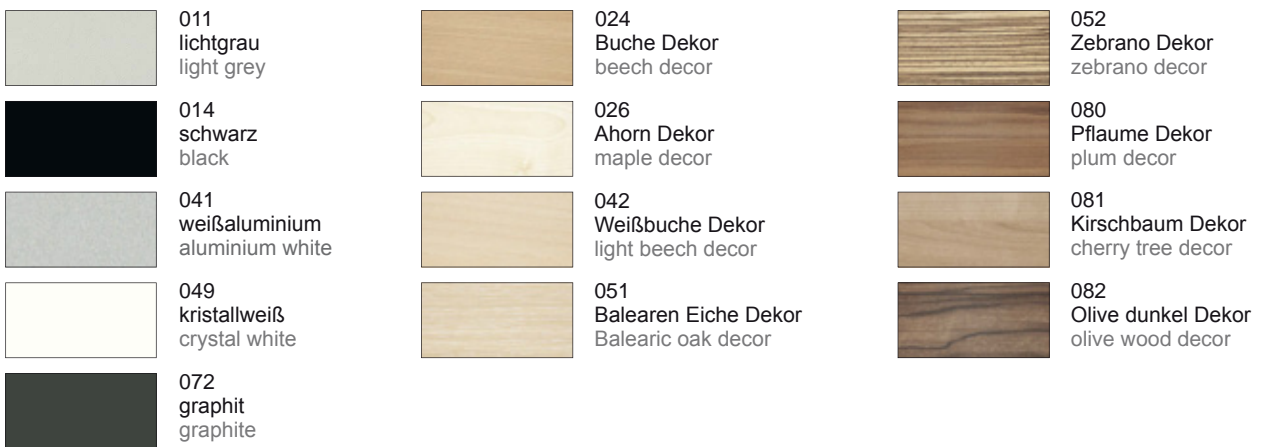

Lowboard: Front, Abdeckplatte; Technikcontainer: Blenden/Abdeckplatte;
Anstallelement: Front/Abdeckplatte (Furnier Echtholz)
Lowboard: front, top; pedestals: blinds/top;
side cupboard unit: front/top (veneer surface real wood)

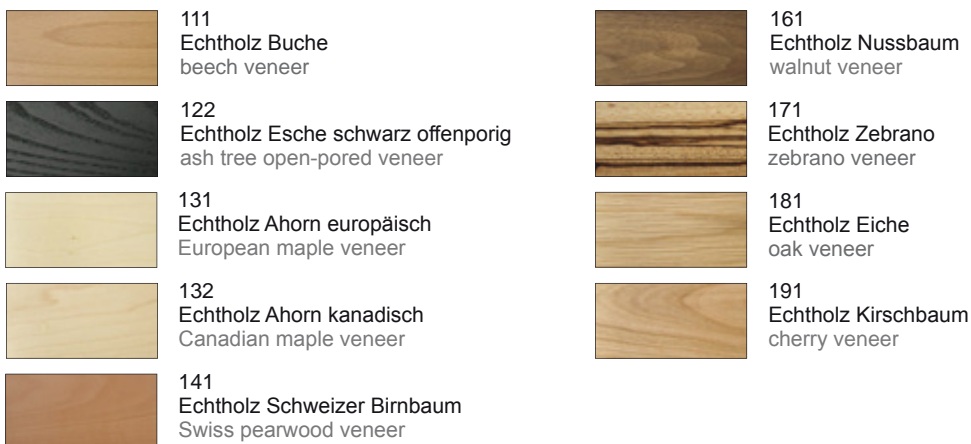

Lowboard: Front; Technikcontainer: Blenden/Abdeckplatte (Lack)
Lowboard: front; pedestal: blinds/top (lacquer)



Rückwände: Metallteile*; Anstellelement: Traversenrohre*
Modesty panels: metal parts*; side cupboard unit: cross bars*

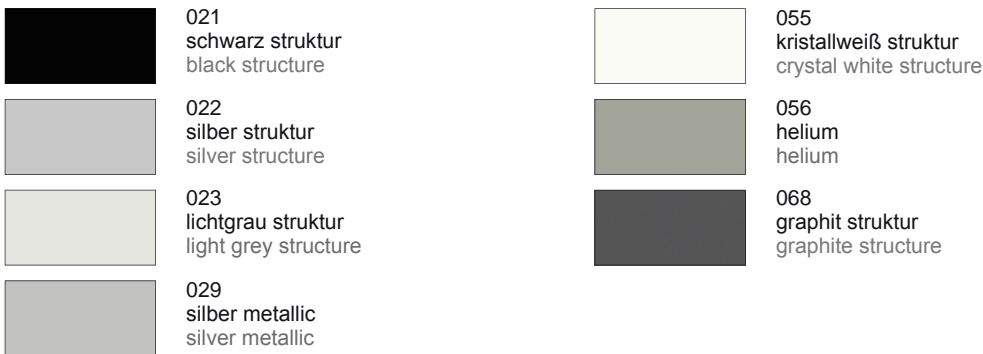

Wichtiger Hinweis:

Holz ist ein gewachsener Werkstoff. Kein Stamm gleicht dem anderen. Die einzelnen Stämme unterscheiden sich in Maserung und Farbe. Aber auch innerhalb eines Stammes treten Struktur- und Tonunterschiede auf. Unter Lichteinwirkung und durch extrem feuchtes oder trockenes Klima kann sich die Holzfarbe ändern. Unterschiede, Unregelmäßigkeiten und Veränderungen, die aufgrund der natürlichen Beschaffenheit des Holzes auftreten, sind kein Grund zur Beanstandung. Die Furniere werden sorgfältig und kommissionsweise ausgewählt. Soweit möglich verwenden wir für einen Auftrag Furnier aus einem Stamm. Dadurch werden die Unterschiede in Struktur und Färbung so gering wie möglich gehalten.

Bei Nachlieferungen sind Unterschiede in Struktur und Färbung kein Grund zur Beanstandung.

Important note:

Wood is a grown material. No trunk of a tree is alike the other. The single trunks are different in grain and colour. Also within a trunk there are differences in structure and tone. When exposed to light radiation and in an extremely humid or extremely dry climate the wood colour can change. Differences and changes caused by the natural quality of the wood are no reason for complaint.

The veneer will be chosen carefully and separately for each commission. As far as possible we use veneer of the same trunk for one order.

This helps to keep differences in structure and colour as low as possible.

Differences in structure and colour are no reason for complaint in subsequent deliveries.

Farbabweichungen zu den Originaloberflächen sind möglich / Colours may vary from actual material

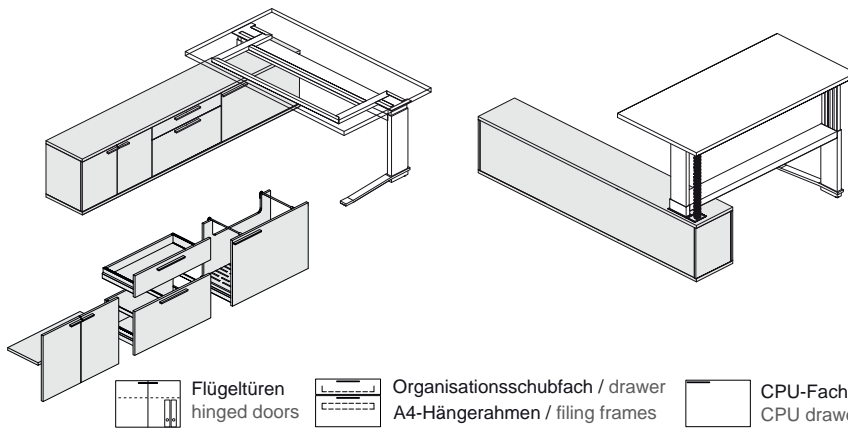
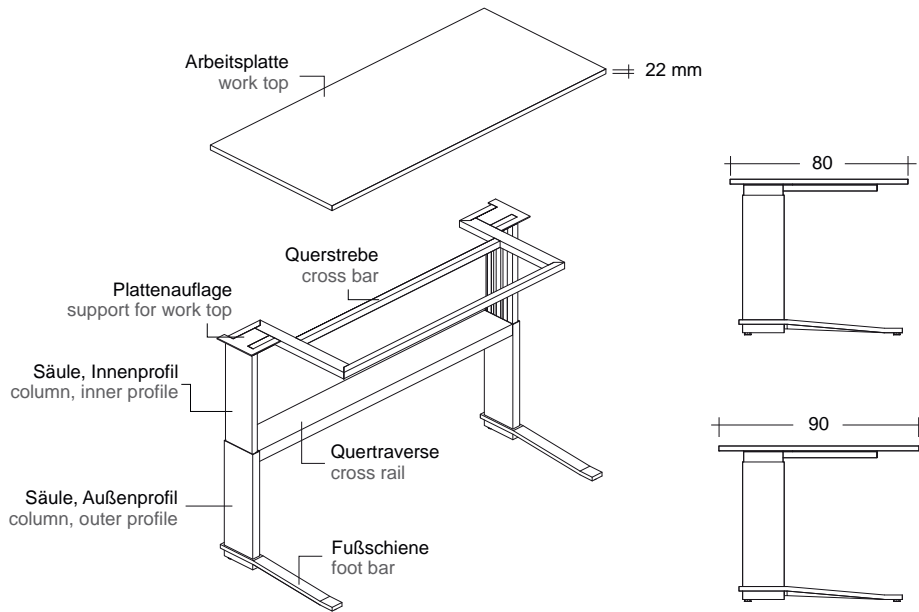

Arbeitstische mit **Lowboard**, 170 oder 250 cm breit, inkl. Kabelkette.
CPU-Fach für Rechner max.
32,8 cm breit, 45 cm hoch, 64,6 cm tief

Work stations with **lowboard**, 170 or 250 cm wide, with cable chain.
CPU drawer for computers max.
32,8 cm wide, 45 cm high, 64,6 cm deep.

Arbeitstische mit **Technikcontainer**, inkl. Kabelkette.
CPU-Fach für Rechner max.
21 cm breit, 46 cm hoch, 53 cm tief

Work stations with **pedestals for files and hardware**, with cable chain.
CPU drawer for computers max.
21 cm wide, 46 cm high, 53 cm deep.

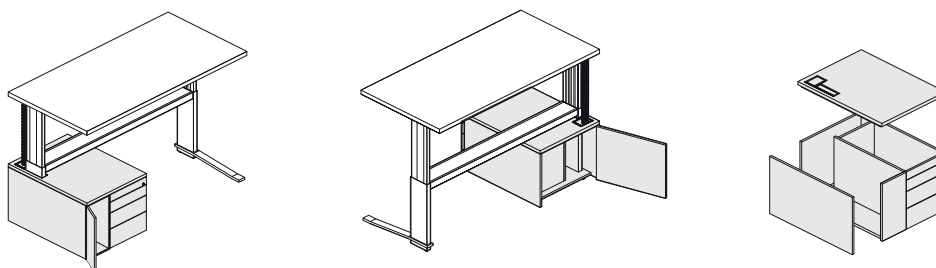

Die Arbeitsplatten für Tische mit Korpusunterbauten sind 3 cm breiter als die Standardmaße, um einen bündigen Abschluss mit dem Korpus zu gewährleisten.

The work tops for desks with a lowboard or pedestal carcass are 3 cm wider than the standard tops in order to be flush with the carcass.

Höhenverstellung

height adjustment

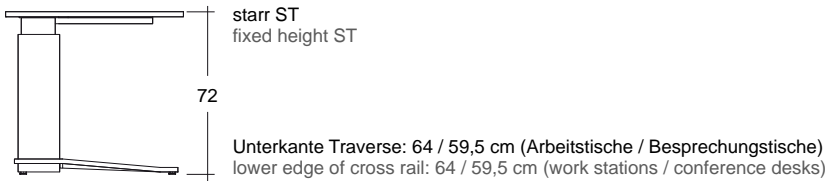

- Arbeitshöhe 72 cm
- **starr ST**
- bis 120 kg belastbar
- working height 72 cm
- **fixed height ST**
- weight load up to 120 kg

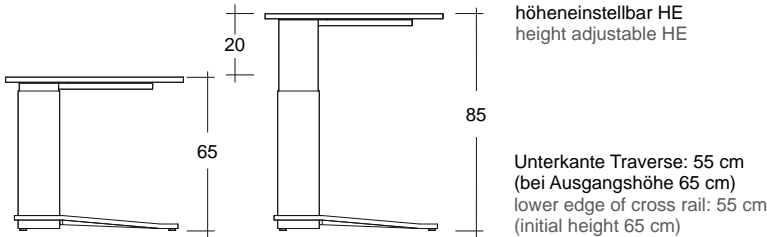

- Arbeitshöhe 72 cm
- **höhenstellbar HE**
- Ausgangshöhe einstellbar von 65 - 85 cm
in 1 cm Schritten, werkzeugfrei
- bis 120 kg belastbar
- working height 72 cm
- **height adjustable HE**
- initial height adjustable from 65 - 85 cm
in 1 cm steps
- continuously locking
- weight load up to 120 kg in fixed position

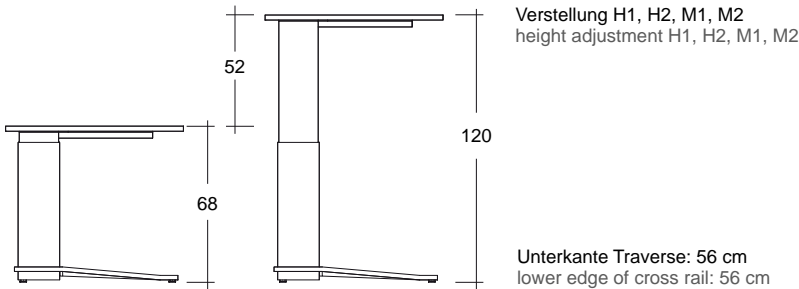

- Ausgangshöhe 68 cm
- **Manuelle Verstellung H1**
- Schnellverstellung
- 3 Gewichtsklassen: 0 - 15, 15 - 30, 30 - 45 kg
- stufenlose Arretierung, bis 120 kg belastbar
- **Manuelle Verstellung H2**
- mit Gewichtsausgleich zur Abstimmung
auf variable Tischlasten
- 3 Gewichtsklassen: 0 - 40, 20 - 60, 40 - 80 kg
- stufenlose Arretierung, bis 120 kg belastbar
- **Motorverstellung M1**
- im Gestell integrierter, leise laufender
Elektromotor
- Verstellgeschwindigkeit: ca. 70 mm/s
- Geräusentwicklung < als 55 dBA
- Belastung 0 - 75 kg, optional 40 - 115 kg
- Softstart, Softstop
- **Motorverstellung M2**
- optional Komfortsteuerung mit Höhenanzeige
und 4 Memory-Positionen

Verstellarten / type of adjustment:

Verstellung / adjustment	Belastung / weight bearing
ST starr / fixed height	---
HE höhenstellbar / height adjustable	---
H1 Hand / hand	0 - 15 kg
H2 Hand mit Gewichtsausgleich / hand, with weight compensation	0 - 40 kg
M1 Motor, Einfachsteuerung / motor, up and down	0 - 75 kg
M2 Motor, Komfortsteuerung / motor, with memory function	0 - 75 kg

Option Zusatzgewichte / option additional weight:

	standard	Z1	Z2	Z3	Z4	ZM
H1	0 - 15 kg	15 - 30 kg	30 - 45 kg			
H2	0 - 40 kg			20 - 60 kg	40 - 80 kg	
M1	0 - 75 kg					40 - 115 kg
M2	0 - 75 kg					40 - 115 kg

- initial working height 68 cm
- **height adjustment by hand H1**
- quick adjustment
- 3 weight classes: 0 - 15, 15 - 30, 30 - 45 kg
- continuously locking up to 120 kg
- **height adjustment by hand H2**
- with weight compensation for different
imposed loads
- 3 weight classes: 0 - 40, 20 - 60, 40 - 80 kg
- continuously locking up to 120 kg
- **height adjustment by motor M1**
- quiet electro motor integrated in the frame
- speed of adjustability: approx. 70 mm/s
- noise development less than 55 dBA
- weight bearing 0 - 75 kg, option 40 - 115 kg
- softstart, softstop
- **height adjustment by motor M2**
- option: comfort control including LED display
and 4 memory positions

Kabelmanagement

cable management

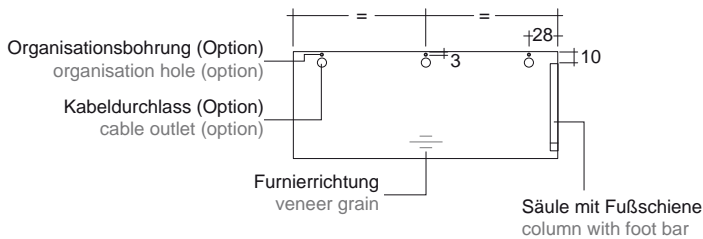
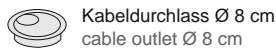
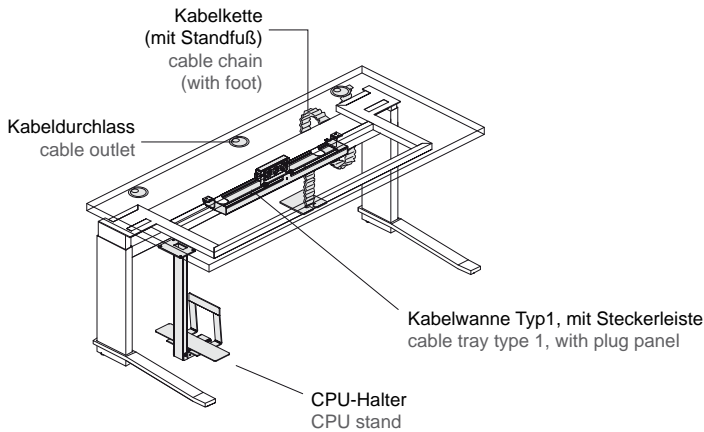

Horizontale Kabelführung:

- Kabeldurchlässe, Ø 8 cm, aus Kunststoff und Metall, Positionen einzeln wählbar
- Kabelwanne Typ 1: 60 cm breit, für rechteckige und angewinkelte Arbeitstische, Schenkellänge 120 cm (Platten 03 - 10), sonst 80 cm breite Kabelwanne (auch für Eckarbeitstische)
- Kabelbügel, Desktop-Steckerleisten, siehe separate Preisliste "Systemverkabelung"

Vertikale Kabelführung:

- Kabelkette mit Standfuß
- **Weitere Option:**
- sinnvolle Anzahl von Organisationsbohrungen an der Hinterkante der Arbeitsplatte zur Aufnahme von Monitorarm oder Aufsatzwand bzw. zur Verschraubung von handelsüblichem Zubehör

horizontal cabling:

- cable outlets, Ø 8 cm, made of plastic or metal, positions individually selectable
- cable tray type 1: 60 cm wide for rectangular and angled work stations with side length 120 cm (tops 03-10), for all other tops 80 cm width (also for corner work stations)
- cable bow, desktop power modules, see separate price list "Electrical Accessories"

vertical cabling:

- cable chain with foot
- **further option:**
- useful number of organisation holes on the rear edge of the work top for the reception of monitor arm or partition wall as well as for the fixing of customary accessories.

Kabelwanne, abklappbar
cable tray, swinging downboards for easy access

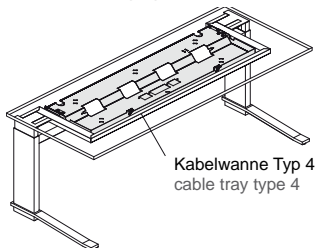

Kabelwanne für höhenverstellbare Besprechungstische
cable tray for height adjustable conference desks

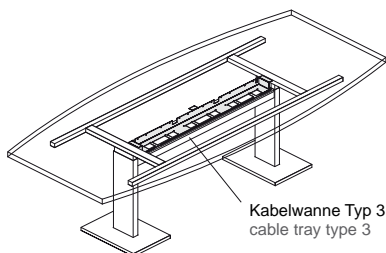

Weiteres Zubehör siehe separate Preisliste "Systemverkabelung"!
Further accessories see separate price list "Electrical Accessories"!

Verstellart / adjustment:

ST: starr / fixed height

HE: höhenstellbar / height adjustable

H1: Hand / hand

H2: Hand mit Gewichtsausgleich / hand, with weight compensation

M1: Motor, Einfachsteuerung / motor, up and down

M2: Motor, Komfortsteuerung / motor, with memory function

Belastung / weight bearing:

H1: 0 - 15 kg

H2: 0 - 40 kg / ** 0-30 kg

M1: 0 - 75 kg

M2: 0 - 75 kg

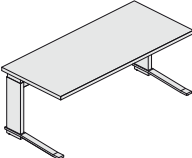
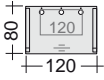
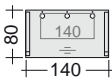
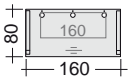
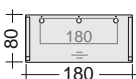
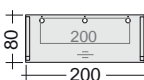
Arbeitsstische, 80 cm tief		work stations, 80 cm deep			
	Trägermaterial: Oberfläche:	Spanplatte (22) Melamin	Spanplatte (22) Echtholz	Säulenprofile* Alu gebürstet farblos eloxiert 075	Fußschienen Aluminium poliert 076
	basic material: surface:	chipboard (22) melamine	chipboard (22) real wood veneer	columns* alu brushed clear anodised 075	foot bars polished aluminium 076
		SM	SF		
	IMC2TR1-12-ST- **			-FO2	-FO3
	IMC2TR1-12-HE- **			-FO2	-FO3
	IMC2TR1-12-H1- **			-FO2	-FO3
	** IMC2TR1-12-H2- **			-FO2	-FO3
	IMC2TR1-12-M1- **			-FO2	-FO3
	IMC2TR1-12-M2- **			-FO2	-FO3
	IMC2TR1-14-ST- **			-FO2	-FO3
	IMC2TR1-14-HE- **			-FO2	-FO3
	IMC2TR1-14-H1- **			-FO2	-FO3
	IMC2TR1-14-H2- **			-FO2	-FO3
	IMC2TR1-14-M1- **			-FO2	-FO3
	IMC2TR1-14-M2- **			-FO2	-FO3
	IMC2TR1-16-ST- **			-FO2	-FO3
	IMC2TR1-16-HE- **			-FO2	-FO3
	IMC2TR1-16-H1- **			-FO2	-FO3
	IMC2TR1-16-H2- **			-FO2	-FO3
	IMC2TR1-16-M1- **			-FO2	-FO3
	IMC2TR1-16-M2- **			-FO2	-FO3
	IMC2TR1-18-ST- **			-FO2	-FO3
	IMC2TR1-18-HE- **			-FO2	-FO3
	IMC2TR1-18-H1- **			-FO2	-FO3
	IMC2TR1-18-H2- **			-FO2	-FO3
	IMC2TR1-18-M1- **			-FO2	-FO3
	IMC2TR1-18-M2- **			-FO2	-FO3
	IMC2TR1-20-ST- **			-FO2	-FO3
	IMC2TR1-20-HE- **			-FO2	-FO3
	IMC2TR1-20-H1- **			-FO2	-FO3
	IMC2TR1-20-H2- **			-FO2	-FO3
	IMC2TR1-20-M1- **			-FO2	-FO3
	IMC2TR1-20-M2- **			-FO2	-FO3
Notwendige Farbangaben / Necessary colour details:		1. Gestell / frame		3. Platte / top	
		2. Fußschienen / foot bars		1. Gestell / frame	
				2. Fußschienen / foot bars	

Weitere Optionen			further options
Option	Beschreibung	description	Preis / price
-K1L/-K1R/-K1M	Kabeldurchlass aus Kunststoff links, rechts, mittig	cable outlet made of plastic left, right, central position	à
-K2L/-K2R/-K2M	Kabeldurchlass aus Metall links, rechts, mittig	cable outlet made of metal left, right, central position	à
Notwendige Farbangabe / Necessary colour detail:			4. Kabeldurchlass / cable outlet
-OBM1	Organisationsbohrungen	organisation holes	
-Z1	höheres Zusatzgewicht für H1 (15-30 kg)	higher additional weight for H1 (15-30 kg)	
-Z2	höheres Zusatzgewicht für H1 (30-45 kg)	higher additional weight for H1 (30-45 kg)	
-Z3	höheres Zusatzgewicht für H2 (20-60 kg)	higher additional weight for H2 (20-60 kg)	
-Z4	höheres Zusatzgewicht für H2 (40-80 kg)	higher additional weight for H2 (40-80 kg)	
-ZM	höheres Zusatzgewicht für M1 und M2 (40-115 kg)	higher additional weight for M1 and M2 (40-115 kg)	

* Option -FO2: Säulenprofil Aluminium gebürstet farblos eloxiert 075, Gestell silber metallic 029

* option -FO2: columns aluminium brushed clear anodised 075, frame silver metallic 029

Verstellart / adjustment:

ST: starr / fixed height

HE: höhenstellbar / height adjustable

H1: Hand / hand

H2: Hand mit Gewichtsausgleich / hand, with weight compensation

M1: Motor, Einfachsteuerung / motor, up and down

M2: Motor, Komfortsteuerung / motor, with memory function

Belastung / weight bearing:

H1: 0 - 15 kg

H2: 0 - 40 kg / ** 0-30 kg

M1: 0 - 75 kg

M2: 0 - 75 kg

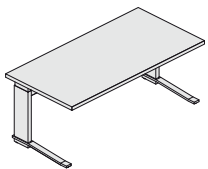
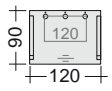
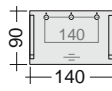
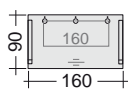
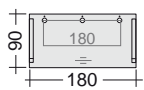
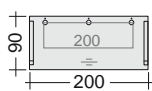
Arbeitstische, 90 cm tief		work stations, 90 cm deep					
	Trägermaterial: Oberfläche:	Spanplatte (22) Melamin	Spanplatte (22) Echtholz	Säulenprofile* Alu gebürstet farblos eloxiert 075	Fußschiene Aluminium poliert 076		
	basic material: surface:	chipboard (22) melamine	chipboard (22) real wood veneer	columns* alu brushed clear anodised 075	foot bars polished aluminium 076		
		SM	SF				
	IMC2TR2-12-ST- **			-FO2		-FO3	
	IMC2TR2-12-HE- **			-FO2		-FO3	
	IMC2TR2-12-H1- **			-FO2		-FO3	
	** IMC2TR2-12-H2- **			-FO2		-FO3	
	IMC2TR2-12-M1- **			-FO2		-FO3	
	IMC2TR2-12-M2- **			-FO2		-FO3	
	IMC2TR2-14-ST- **			-FO2		-FO3	
	IMC2TR2-14-HE- **			-FO2		-FO3	
	IMC2TR2-14-H1- **			-FO2		-FO3	
	IMC2TR2-14-H2- **			-FO2		-FO3	
	IMC2TR2-14-M1- **			-FO2		-FO3	
	IMC2TR2-14-M2- **			-FO2		-FO3	
	IMC2TR2-16-ST- **			-FO2		-FO3	
	IMC2TR2-16-HE- **			-FO2		-FO3	
	IMC2TR2-16-H1- **			-FO2		-FO3	
	IMC2TR2-16-H2- **			-FO2		-FO3	
	IMC2TR2-16-M1- **			-FO2		-FO3	
	IMC2TR2-16-M2- **			-FO2		-FO3	
	IMC2TR2-18-ST- **			-FO2		-FO3	
	IMC2TR2-18-HE- **			-FO2		-FO3	
	IMC2TR2-18-H1- **			-FO2		-FO3	
	IMC2TR2-18-H2- **			-FO2		-FO3	
	IMC2TR2-18-M1- **			-FO2		-FO3	
	IMC2TR2-18-M2- **			-FO2		-FO3	
	IMC2TR2-20-ST- **			-FO2		-FO3	
	IMC2TR2-20-HE- **			-FO2		-FO3	
	IMC2TR2-20-H1- **			-FO2		-FO3	
	IMC2TR2-20-H2- **			-FO2		-FO3	
	IMC2TR2-20-M1- **			-FO2		-FO3	
	IMC2TR2-20-M2- **			-FO2		-FO3	
Notwendige Farbangaben / Necessary colour details:		1. Gestell / frame		3. Platte / top		1. Gestell / frame	
		2. Fußschiene / foot bars				2. Fußschiene / foot bars	

Weitere Optionen further options

Option	Beschreibung	description	Preis / price
-K1L/-K1R/-K1M	Kabeldurchlass aus Kunststoff links, rechts, mittig	cable outlet made of plastic left, right, central position	à
-K2L/-K2R/-K2M	Kabeldurchlass aus Metall links, rechts, mittig	cable outlet made of metal left, right, central position	à
Notwendige Farbangabe / Necessary colour detail:		4. Kabeldurchlass / cable outlet	
-OBM1	Organisationsbohrungen	organisation holes	
-Z1	höheres Zusatzgewicht für H1 (15-30 kg)	higher additional weight for H1 (15-30 kg)	
-Z2	höheres Zusatzgewicht für H1 (30-45 kg)	higher additional weight for H1 (30-45 kg)	
-Z3	höheres Zusatzgewicht für H2 (20-60 kg)	higher additional weight for H2 (20-60 kg)	
-Z4	höheres Zusatzgewicht für H2 (40-80 kg)	higher additional weight for H2 (40-80 kg)	
-ZM	höheres Zusatzgewicht für M1 und M2 (40-115 kg)	higher additional weight for M1 and M2 (40-115 kg)	

* Option -FO2: Säulenprofil Aluminium gebürstet farblos eloxiert 075, Gestell silber metallic 029

* option -FO2: columns aluminium brushed clear anodised 075, frame silver metallic 029

Verstellart / adjustment:

ST: starr / fixed height

HE: Höheneinstellung / height adjustable

H1: Hand / hand

H2: Hand mit Gewichtsausgleich / hand, with weight compensation

M1: Motor, Einfachsteuerung / motor, up and down

M2: Motor, Komfortsteuerung / motor, with memory function

Belastung / weight bearing:

H1: 0 - 15 kg

H2: 0 - 40 kg

M1: 0 - 75 kg

M2: 0 - 75 kg

Arbeitsstische für Korpusunterbau links		work stations for pedestal or lowboard left side			
	Trägermaterial: Oberfläche:	Spanplatte (22) Melamin	Spanplatte (22) Echtholz	Säulenprofile* Alu gebürstet farblos eloxiert 075	Fußschiene Aluminium poliert 076
	basic material: surface:	chipboard (22) melamine	chipboard (22) real wood veneer	columns* alu brushed clear anodised 075	foot bars polished aluminium 076
		SM	SF		
	IMCLTR2-18-ST- **			-FO2	-FO3
	IMCLTR2-18-HE- **			-FO2	-FO3
	IMCLTR2-18-H1- **			-FO2	-FO3
	IMCLTR2-18-H2- **			-FO2	-FO3
	IMCLTR2-18-M1- **			-FO2	-FO3
	IMCLTR2-18-M2- **			-FO2	-FO3
	IMCLTR2-20-ST- **			-FO2	-FO3
	IMCLTR2-20-HE- **			-FO2	-FO3
	IMCLTR2-20-H1- **			-FO2	-FO3
	IMCLTR2-20-H2- **			-FO2	-FO3
	IMCLTR2-20-M1- **			-FO2	-FO3
	IMCLTR2-20-M2- **			-FO2	-FO3
	IMCLTR2-22-ST- **			-FO2	-FO3
	IMCLTR2-22-HE- **			-FO2	-FO3
	IMCLTR2-22-H1- **			-FO2	-FO3
	IMCLTR2-22-H2- **			-FO2	-FO3
	IMCLTR2-22-M1- **			-FO2	-FO3
	IMCLTR2-22-M2- **			-FO2	-FO3
Notwendige Farbangaben / Necessary colour details:		1. Gestell / frame		3. Platte / top	
		2. Fußschiene / foot bars		1. Gestell / frame	
				2. Fußschiene / foot bars	

Weitere Optionen			Further options
Option	Beschreibung	description	Preis / price
-K1L/-K1R/-K1M	Kabeldurchlass aus Kunststoff links, rechts, mittig	cable outlet made of plastic left, right, central position	à
-K2L/-K2R/-K2M	Kabeldurchlass aus Metall links, rechts, mittig	cable outlet made of metal left, right, central position	à
Notwendige Farbangabe / Necessary colour detail:			4. Kabeldurchlass / cable outlet
-OBM1	Organisationsbohrungen	organisation holes	
-Z1	höheres Zusatzgewicht für H1 (15-30 kg)	higher additional weight for H1 (15-30 kg)	
-Z2	höheres Zusatzgewicht für H1 (30-45 kg)	higher additional weight for H1 (30-45 kg)	---
-Z3	höheres Zusatzgewicht für H2 (20-60 kg)	higher additional weight for H2 (20-60 kg)	---
-Z4	höheres Zusatzgewicht für H2 (40-80 kg)	higher additional weight for H2 (40-80 kg)	---
-ZM	höheres Zusatzgewicht für M1 und M2 (40-115 kg)	higher additional weight for M1 and M2 (40-115 kg)	---

* Option -FO2: Säulenprofil Aluminium gebürstet farblos eloxiert 075, Gestell silber metallic 029

* option -FO2: columns aluminium brushed clear anodised 075, frame silver metallic 029

Verstellart / adjustment:

ST: starr / fixed height

HE: Höheneinstellung / height adjustable

H1: Hand / hand

H2: Hand mit Gewichtsausgleich / hand, with weight compensation

M1: Motor, Einfachsteuerung / motor, up and down

M2: Motor, Komfortsteuerung / motor, with memory function

Belastung / weight bearing:

H1: 0 - 15 kg

H2: 0 - 40 kg

M1: 0 - 75 kg

M2: 0 - 75 kg

Arbeitstische für Korpusunterbau rechts		work stations for pedestal or lowboard right side			
	Trägermaterial: Oberfläche:	Spanplatte (22) Melamin	Spanplatte (22) Echtholz	Säulenprofile* Alu gebürstet farblos eloxiert 075	Fußschiene Aluminium poliert 076
	basic material: surface:	chipboard (22) melamine	chipboard (22) real wood veneer	columns* alu brushed clear anodised 075	foot bars polished aluminium 076
		SM	SF		
	IMCRTR2-18-ST- **			-FO2	-FO3
	IMCRTR2-18-HE- **			-FO2	-FO3
	IMCRTR2-18-H1- **			-FO2	-FO3
	IMCRTR2-18-H2- **			-FO2	-FO3
	IMCRTR2-18-M1- **			-FO2	-FO3
	IMCRTR2-18-M2- **			-FO2	-FO3
	IMCRTR2-20-ST- **			-FO2	-FO3
	IMCRTR2-20-HE- **			-FO2	-FO3
	IMCRTR2-20-H1- **			-FO2	-FO3
	IMCRTR2-20-H2- **			-FO2	-FO3
	IMCRTR2-20-M1- **			-FO2	-FO3
	IMCRTR2-20-M2- **			-FO2	-FO3
	IMCRTR2-22-ST- **			-FO2	-FO3
	IMCRTR2-22-HE- **			-FO2	-FO3
	IMCRTR2-22-H1- **			-FO2	-FO3
	IMCRTR2-22-H2- **			-FO2	-FO3
	IMCRTR2-22-M1- **			-FO2	-FO3
	IMCRTR2-22-M2- **			-FO2	-FO3
Notwendige Farbangaben / Necessary colour details:		1. Gestell / frame		1. Gestell / frame	
		2. Fußschiene / foot bars		2. Fußschiene / foot bars	
		3. Platte / top			

Weitere Optionen			further options
Option	Beschreibung	description	Preis / price
-K1L/-K1R/-K1M	Kabeldurchlass aus Kunststoff links, rechts, mittig	cable outlet made of plastic left, right, central position	à
-K2L/-K2R/-K2M	Kabeldurchlass aus Metall links, rechts, mittig	cable outlet made of metal left, right, central position	à
Notwendige Farbangabe / Necessary colour detail:			4. Kabeldurchlass / cable outlet
-OBM1	Organisationsbohrungen	organisation holes	
-Z1	höheres Zusatzgewicht für H1 (15-30 kg)	higher additional weight for H1 (15-30 kg)	---
-Z2	höheres Zusatzgewicht für H1 (30-45 kg)	higher additional weight for H1 (30-45 kg)	---
-Z3	höheres Zusatzgewicht für H2 (20-60 kg)	higher additional weight for H2 (20-60 kg)	---
-Z4	höheres Zusatzgewicht für H2 (40-80 kg)	higher additional weight for H2 (40-80 kg)	---
-ZM	höheres Zusatzgewicht für M1 und M2 (40-115 kg)	higher additional weight for M1 and M2 (40-115 kg)	---

* Option -FO2: Säulenprofil Aluminium gebürstet farblos eloxiert 075, Gestell silber metallic 029

* option -FO2: columns aluminium brushed clear anodised 075, frame silver metallic 029

Verstellart / adjustment:

ST: starr / fixed height

HE: Höheneinstellung / height adjustable

H2: Hand mit Gewichtsausgleich / hand, with weight compensation

M1: Motor, Einfachsteuerung / motor, up and down

M2: Motor, Komfortsteuerung / motor, with memory function

Belastung / weight bearing:

H2: 0 - 40 kg

M1: 0 - 75 kg

M2: 0 - 75 kg

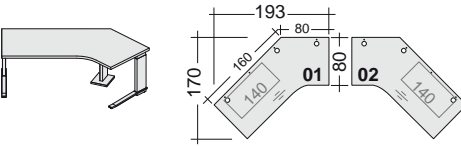
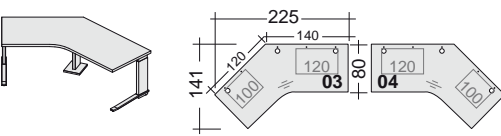
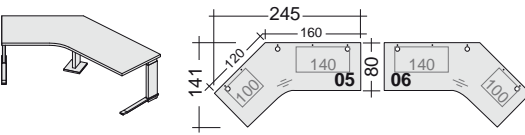
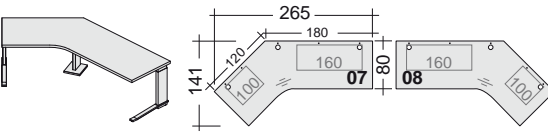
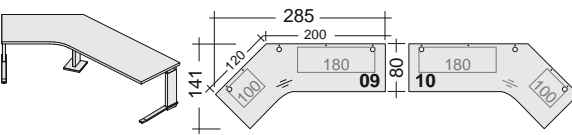
Arbeitsstische, angewinkelt		angled work stations				
Plattenform / work top shape		Trägermaterial: Oberfläche:	Spanplatte (22) Melamin	Spanplatte (22) Echtholz	Säulenprofile* Alu gebürstet farblos eloxiert 075	Fußschienen Aluminium poliert 076
		basic material: surface:	chipboard (22) melamine	chipboard (22) r. wood veneer	columns* alu brushed clear anodised 075	foot bars polished aluminium 076
			SM	SF		
	IMC2TA1-**-ST-**-01				-FO2	-FO3
	IMC2TA1-**-HE-**-02				-FO2	-FO3
	IMC2TA1-**-H2-**-01				-FO2	-FO3
	IMC2TA1-**-M1-**-01				-FO2	-FO3
	IMC2TA1-**-M2-**-01				-FO2	-FO3
	IMC2TA1-**-ST-**-03				-FO2	-FO3
	IMC2TA1-**-HE-**-04				-FO2	-FO3
	IMC2TA1-**-H2-**-03				-FO2	-FO3
	IMC2TA1-**-M1-**-03				-FO2	-FO3
	IMC2TA1-**-M2-**-03				-FO2	-FO3
	IMC2TA1-**-ST-**-05				-FO2	-FO3
	IMC2TA1-**-HE-**-06				-FO2	-FO3
	IMC2TA1-**-H2-**-05				-FO2	-FO3
	IMC2TA1-**-M1-**-05				-FO2	-FO3
	IMC2TA1-**-M2-**-05				-FO2	-FO3
	IMC2TA1-**-ST-**-07				-FO2	-FO3
	IMC2TA1-**-HE-**-08				-FO2	-FO3
	IMC2TA1-**-H2-**-07				-FO2	-FO3
	IMC2TA1-**-M1-**-07				-FO2	-FO3
	IMC2TA1-**-M2-**-07				-FO2	-FO3
	IMC2TA1-**-ST-**-09				-FO2	-FO3
	IMC2TA1-**-HE-**-10				-FO2	-FO3
	IMC2TA1-**-H2-**-09				-FO2	-FO3
	IMC2TA1-**-M1-**-09				-FO2	-FO3
	IMC2TA1-**-M2-**-09		3.051,-		-FO2	-FO3
Notwendige Farbangaben / Necessary colour details:		1. Gestell / frame	3. Platte / top		1. Gestell / frame	2. Fußschienen / foot bars
		2. Fußschienen / foot b.				

Weitere Optionen		further options	
Option	Beschreibung	description	Preis / price
-K1L/-K1R/-K1M	Kabeldurchlass aus Kunststoff links, rechts, mittig	cable outlet made of plastic left, right, central position	à
-K2L/-K2R/-K2M	Kabeldurchlass aus Metall links, rechts, mittig	cable outlet made of metal left, right, central position	à
Notwendige Farbangabe / Necessary colour detail:		4. Kabeldurchlass / cable outlet	
-OBM1	Organisationsbohrungen	organisation holes	
-Z3	höheres Zusatzgewicht für H2 (20-60 kg)	higher additional weight for H2 (20-60 kg)	
-Z4	höheres Zusatzgewicht für H2 (40-80 kg)	higher additional weight for H2 (40-80 kg)	
-ZM	höheres Zusatzgewicht für M1 und M2 (40-115 kg)	higher additional weight for M1 and M2 (40-115 kg)	

* Option -FO2: Säulenprofil Aluminium gebürstet farblos eloxiert 075, Gestell silber metallic 029

* option -FO2: columns aluminium brushed clear anodised 075, frame silver metallic 029

Arbeitstische, Eckform (1 Platte)

Corner work stations (1 top)

Verstellart / adjustment:

ST: starr / fixed height

HE: Höheneinstellung / height adjustable

H2: Hand mit Gewichtsausgleich / hand, with weight compensation

M1: Motor, Einfachsteuerung / motor, up and down

M2: Motor, Komfortsteuerung / motor, with memory function

Belastung / weight bearing:

H2: 0 - 40 kg

M1: 0 - 75 kg

M2: 0 - 75 kg

Arbeitstische, Eckform (1 Platte)		corner work stations, (1 top)				
Plattenform / work top shape		Trägermaterial: Oberfläche:	Spanplatte (22) Melamin	Spanplatte (22) Echtholz	Säulenprofile* Alu gebürstet farblos eloxiert 075	Fußschienen Aluminium poliert 076
		basic material: surface:	chipboard (22) melamine	chipboard (22) r. wood veneer	columns* alu brushed clear anodised 075	foot bars polished aluminium 076
			SM	SF		
		IMC2TE1- ** ST- **			-FO2	-FO3
		IMC2TE1- ** HE- **			-FO2	-FO3
		IMC2TE1- ** H2- **			-FO2	-FO3
		IMC2TE1- ** M1- **			-FO2	-FO3
		IMC2TE1- ** M2- **			-FO2	-FO3
		IMC2TE1- ** ST- **			-FO2	-FO3
		IMC2TE1- ** HE- **			-FO2	-FO3
		IMC2TE1- ** H2- **			-FO2	-FO3
		IMC2TE1- ** M1- **			-FO2	-FO3
		IMC2TE1- ** M2- **			-FO2	-FO3
		IMC2TE1- ** ST- **			-FO2	-FO3
		IMC2TE1- ** HE- **			-FO2	-FO3
		IMC2TE1- ** H2- **			-FO2	-FO3
		IMC2TE1- ** M1- **			-FO2	-FO3
		IMC2TE1- ** M2- **			-FO2	-FO3
Notwendige Farbangaben / Necessary colour details:		1. Gestell / frame	3. Platte / top		1. Gestell / frame	2. Fußschienen / foot bars
		2. Fußschienen / foot b.				

Arbeitstische, Eckform (2 Platten) - komplett höhenverstellbar		corner work stations, (2 tops) - completely high adjustable				
Plattenform / work top shape			SM	SF		
		IMC2TE3- ** ST- **			-FO2	-FO3
		IMC2TE3- ** HE- **			-FO2	-FO3
		IMC2TE3- ** H2- **			-FO2	-FO3
		IMC2TE3- ** M1- **			-FO2	-FO3
		IMC2TE3- ** M2- **			-FO2	-FO3
		IMC2TE3- ** ST- **			-FO2	-FO3
		IMC2TE3- ** HE- **			-FO2	-FO3
		IMC2TE3- ** H2- **			-FO2	-FO3
		IMC2TE3- ** M1- **			-FO2	-FO3
		IMC2TE3- ** M2- **			-FO2	-FO3
Notwendige Farbangaben / Necessary colour details:		1. Gestell / frame	3. Platte / top		1. Gestell / frame	2. Fußschienen / foot bars
		2. Fußschienen / foot b.				

Weitere Optionen			further options
Option	Beschreibung	description	Preis / price
-K1L/-K1R/-K1M	Kabeldurchlass aus Kunststoff links, rechts, mittig	cable outlet made of plastic left, right, central position	à
-K2L/-K2R/-K2M	Kabeldurchlass aus Metall links, rechts, mittig	cable outlet made of metal left, right, central position	à
Notwendige Farbangabe / Necessary colour detail:			4. Kabeldurchlass / cable outlet
-OBM1	Organisationsbohrungen	organisation holes	
-Z3	höheres Zusatzgewicht für H2 (20-60 kg)	higher additional weight for H2 (20-60 kg)	
-Z4	höheres Zusatzgewicht für H2 (40-80 kg)	higher additional weight for H2 (40-80 kg)	
-ZM	höheres Zusatzgewicht für M1 und M2 (40-115 kg)	higher additional weight for M1 and M2 (40-115 kg)	

* Option -FO2: Säulenprofil Aluminium gebürstet farblos eloxiert 075, Gestell silber metallic 029

* option -FO2: columns aluminium brushed clear anodised 075, frame silver metallic 029

Verstellart / adjustment:

ST: starr / fixed height

HE: Höheneinstellung / height adjustable

H1: Hand / hand

H2: Hand mit Gewichtsausgleich / hand, with weight compensation

M1: Motor, Einfachsteuerung / motor, up and down

M2: Motor, Komfortsteuerung / motor, with memory function

Belastung / weight bearing:

H1: 0 - 15 kg

H2: 0 - 40 kg

M1: 0 - 75 kg

M2: 0 - 75 kg

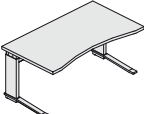
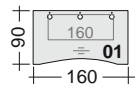
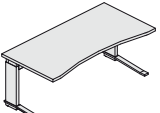
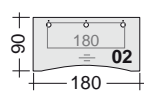
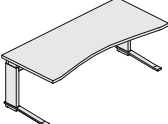
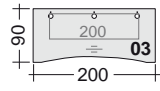
Arbeitsstische, Freiform		free-form work stations				
		Trägermaterial: Oberfläche:	Spanplatte (22) Melamin	Spanplatte (22) Echtholz	Säulenprofile* Alu gebürstet farblos eloxiert 075	Fußschiene Aluminium poliert 076
		basic material: surface:	chipboard (22) melamine	chipboard (22) real wood veneer	columns* alu brushed clear anodised 075	foot bars polished aluminium 076
			SM	SF		
 	IMC2TF2-01-ST- **			-FO2	-FO3	
	IMC2TF2-01-HE- **			-FO2	-FO3	
	IMC2TF2-01-H1- **			-FO2	-FO3	
	IMC2TF2-01-H2- **			-FO2	-FO3	
	IMC2TF2-01-M1- **			-FO2	-FO3	
	IMC2TF2-01-M2- **			-FO2	-FO3	
 	IMC2TF2-02-ST- **			-FO2	-FO3	
	IMC2TF2-02-HE- **			-FO2	-FO3	
	IMC2TF2-02-H1- **			-FO2	-FO3	
	IMC2TF2-02-H2- **			-FO2	-FO3	
	IMC2TF2-02-M1- **			-FO2	-FO3	
	IMC2TF2-02-M2- **			-FO2	-FO3	
 	IMC2TF2-03-ST- **			-FO2	-FO3	
	IMC2TF2-03-HE- **			-FO2	-FO3	
	IMC2TF2-03-H1- **			-FO2	-FO3	
	IMC2TF2-03-H2- **			-FO2	-FO3	
	IMC2TF2-03-M1- **			-FO2	-FO3	
	IMC2TF2-03-M2- **			-FO2	-FO3	
Notwendige Farbangaben / Necessary colour details:		1. Gestell / frame	3. Platte / top		1. Gestell / frame	2. Fußschiene / foot bars
		2. Fußschiene / foot bars				

Weitere Optionen		further options	
Option	Beschreibung	description	Preis / price
-K1L/-K1R/-K1M	Kabeldurchlass aus Kunststoff links, rechts, mittig	cable outlet made of plastic left, right, central position	à
-K2L/-K2R/-K2M	Kabeldurchlass aus Metall links, rechts, mittig	cable outlet made of metal left, right, central position	à
Notwendige Farbangabe / Necessary colour detail:		4. Kabeldurchlass / cable outlet	
-OBM1	Organisationsbohrungen	organisation holes	
-Z1	höheres Zusatzgewicht für H1 (15-30 kg)	higher additional weight for H1 (15-30 kg)	
-Z2	höheres Zusatzgewicht für H1 (30-45 kg)	higher additional weight for H1 (30-45 kg)	
-Z3	höheres Zusatzgewicht für H2 (20-60 kg)	higher additional weight for H2 (20-60 kg)	
-Z4	höheres Zusatzgewicht für H2 (40-80 kg)	higher additional weight for H2 (40-80 kg)	
-ZM	höheres Zusatzgewicht für M1 und M2 (40-115 kg)	higher additional weight for M1 and M2 (40-115 kg)	

* Option -FO2: Säulenprofil Aluminium gebürstet farblos eloxiert 075, Gestell silber metallic 029

* option -FO2: columns aluminium brushed clear anodised 075, frame silver metallic 029

Lowboard, 170 cm breit		lowboard, 170 cm wide					
inkl. Griff -GM/-GN eine Materialschale (Schubfach) Holz-Einlegeboden hinter Flügelür Stellschrauben	1 Frontblock	Kombination 1 Melamin	Kombination 2 Echtholz	Kombination 3 Melamin	komplett verschieß- bar	Griff- option	
	1 Frontblock	Melamin	Echtholz oder Melamin lackiert	Echtholz oder Melamin lackiert			
inclusive handle -GM/-GN one pencil tray (drawer) wooden-shelf behind hinged doors adjusting screws	1 front unit	combination 1 melamine	combination 2 real wood veneer	combination 3 melamine	completely lockable	option handle	
	1 front unit	melamine	real wood veneer or melamine lacquered	real wood veneer or melamine lacquered			
Verstellart Arbeitstisch: A, B* work station adjustment: A, B*		FK1					
	IML1R-01- * -***				-VSK	-GK	---
	IML1L-01- * -***						
	IML1R-02- * -***				-VSK	-GK	---
	IML1L-02- * -***						
	IML1R-03- * -***				-VSK	-GK	---
	IML1L-03- * -***						
Notwendige Farbangaben: Necessary colour detail:	1. Korpus / carcass	2. Frontblock links / front unit left 3. Frontblock rechts / front unit right			4. Kabelkette / cable chain 5. Kabelkettendurchlass cable chain outlet		



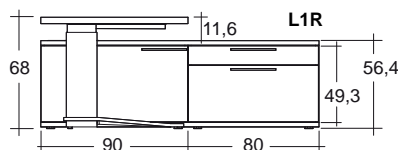
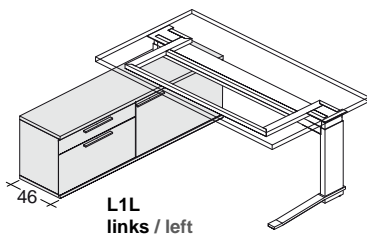

Weitere Option		further option	
Option	Beschreibung	description	Preis / price
-AF	Abdeckplatte Echtholz	top real wood	
Notwendige Farbangaben / Necessary colour details:			6. Abdeckplatte / top

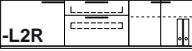

- mit Kabelkettendurchlass und Kabelkette von der Tischplatte in den Korpus
- mit Sichtrückwand, 19 mm, in Korpusfarbe
- with cable chain outlet and cable chain from the desk top to the carcass
- with decorative back panel, 19 mm, colour same as carcass

Zubehör für Organisationsschubfächer		accessories for drawers	
	IMZS03	Facheinteilung längs / drawer partitions lengthwise	IMZS03
	IMZS04	Facheinteilung quer / drawer partitions crosswise	IMZS04
		Materialschale / pencil tray	IMZS05

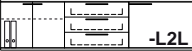
* Verstellart Arbeitstisch: A - starr und höhenstellbar (ST, HE), B - Höhenverstellung (H1, H2, M1, M2)
* work station, adjustment: A - fixed height and initial height adjustable (ST, HE), B - height adjustment (H1, H2, M1, M2)

Lowboard, 250 cm breit		lowboard, 250 cm wide					
inkl. Griff -GM/-GN eine Materialschale (Schubfach) Holz-Einlegeboden hinter Flügeltür Stellschrauben	Frontblöcke links und rechts	Kombination 1 Melamin	Kombination 2 Echtholz	Kombination 3 Melamin	komplett verschieß- bar	Griff- option	
	Frontblöcke Mitte	Melamin	Echtholz oder Melamin lackiert	Echtholz oder Melamin lackiert			
inclusive handle -GM/-GN one pencil tray (drawer) wooden-shelf behind hinged doors adjusting screws	front unit left and right	combination 1 melamine	combination 2 real wood veneer	combination 3 melamine	completely lockable	option handle	
	front unit central	melamine	real wood veneer or melamine lacquered	real wood veneer or melamine lacquered			
Verstellart Arbeitstisch: A, B* work station adjustment: A, B*		FK1	FK2	FK3			
	IML2R-01- * _***				-VSK	-GK	---
	IML2L-01- * _***						
	IML2R-02- * _***				-VSK	-GK	---
	IML2L-02- * _***						
	IML2R-03- * _***				-VSK	-GK	---
	IML2L-03- * _***						
Notwendige Farbangaben: Necessary colour detail:	1. Korpus / carcass	2. Frontblock links und rechts / front unit left and right 3. Frontblock Mitte / front unit central			4. Kabelkette / cable chain 5. Kabelkettendurchlass cable chain outlet		

Weitere Option		further option	
Option	Beschreibung	description	Preis / price
-AF	Abdeckplatte Echtholz	top real wood	
Notwendige Farbangaben / Necessary colour details:			6. Abdeckplatte / top

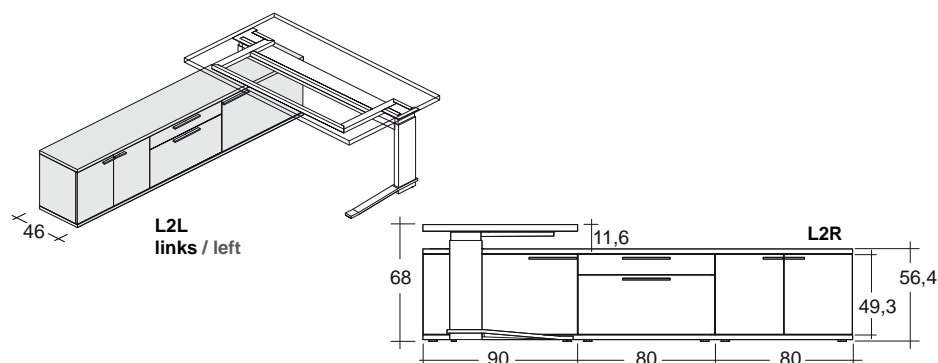

- mit Kabelkettendurchlass und Kabelkette von der Tischplatte in den Korpus
- mit Sichrückwand, 19 mm, in Korpusfarbe
- with cable chain outlet and cable chain from the desk top to the carcass
- with decorative back panel, 19 mm, colour same as carcass

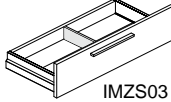
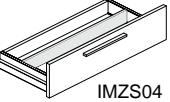
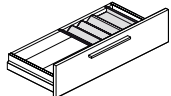
Zubehör für Organisationsschubfächer		accessories for drawers	
		Facheinteilung längs / drawer partitions lengthwise	IMZS03
		Facheinteilung quer / drawer partitions crosswise	IMZS04
		Materialschale / pencil tray	IMZS05

* Verstellart Arbeitstisch: A - starr und höhenverstellbar (ST, HE), B - Höhenverstellung (H1, H2, M1, M2)
* work station, adjustment: A - fixed height and initial height adjustable (ST, HE), B - height adjustment (H1, H2, M1, M2)

Technikcontainer		pedestals for files and hardware					
		Abdeckplatte und Blenden: blinds and top:	Melamin melamine	Echtholz real wood veneer	Für -M1: Abdeckpl./Blenden in 070, 071 For -M1: top/blinds in 070, 071	CPU-Fach verschießbar CPU drawer lockable	
Verstellart Arbeitstisch: A, B* work station adjustment: A, B*			M1	F1			
		IMTC2R-1233- * -**			-FO1	-VS	
		IMTC2L-1233- * -**			-FO1	-VS	
		IMTC2R-126- * -**			-FO1	-VS	
		IMTC2L-126- * -**			-FO1	-VS	
Notwendige Farbangaben: Necessary colour details:		1. Korpus / carcass	2. Abdeckplatte und Blenden / top and blinds		2. Oberfläche Abdeckpl./Blenden top/blinds		
			3. Kabelkettendurchlass / cable chain outlet		4. Kabelkette / cable chain		

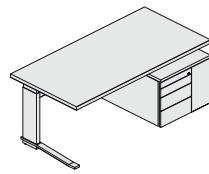
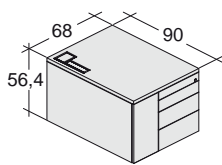

rechts (R)
right (R)

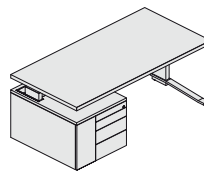

links (L)
left (L)

- mit Kabelkettendurchlass und Kabelkette von der Tischplatte in den Korpus
 - alle Fächer mit Einschubdämpfung
 - Fach 1 voll ausziehbar
 - alle anderen Fächer mit Vollauszug (Überszug), Belastbarkeit bis 45 kg, Kippsicherheit bis 36 kg
 - Inneneinteilung siehe separate Preisliste "desk add"
 - Schubfächer immer verschließbar
CPU-Fach optional verschließbar
- with cable chain outlet and cable chain from the desk top to the carcass
 - all drawers with damped closing
 - drawer 1 with 100% opening
 - all other drawers with >100% opening, load bearing capacity -45 kg, tilting prevention -36 kg
 - accessories see separate price list "desk add"
 - drawers always lockable
CPU drawer optionally lockable

* Verstellart Arbeitstisch: A - starr und höhenverstellbar (ST, HE), B - Höhenverstellung (H1, H2, M1, M2)
* work station, adjustment: A - fixed height and initial height adjustable (ST, HE), B - height adjustment (H1, H2, M1, M2)

Ankettische, Ankettung rechtwinklig add-on desks, 90 deg. connection

		Trägermaterial: Oberfläche:	Spanplatte (22) Melamin	Spanplatte (22) Echtholz	Farboption 077 (passend zu 076)
		basic material: surface:	chipboard (22) melamine	chipboard (22) real wood veneer	colour 077 (matches with 076)
<i>linke und rechte Ankettung möglich / left and right connection possible</i>			SM	SF	
<p>72</p> <p>160</p> <p>60</p> <p>2,5</p> <p>80</p>	<p>IMC1AR3-16-ST- **</p>				-FO5
<p>72</p> <p>180</p> <p>60</p> <p>2,5</p> <p>90</p>	<p>IMC1AR3-18-ST- **</p>				-FO5
<p>Notwendige Farbangaben: Necessary colour details:</p>		<p>1. Gestell / frame</p> <p>2. Fußplatte / foot plate</p>	<p>3. Platte / top</p>		<p>2. Fußplatte foot plate</p>

- **Ankettische nicht in Verbindung mit starren oder höhenstellbaren Arbeitstischen!**
- **Add-on desks are not possible with fixed height desks or desks with initial height adjustment!**

Ankettische Besprechung, Gruppe 2

add-on conference desks, group 2

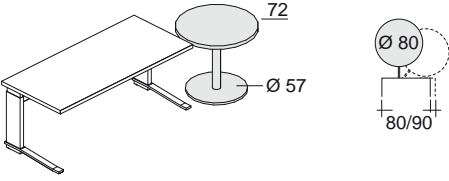
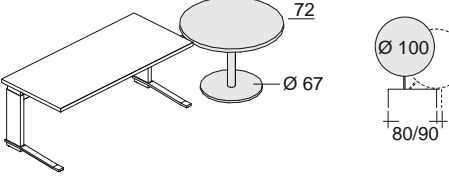
		Trägermaterial: Oberfläche:	Spanplatte (22) Melamin	Spanplatte (22) Echtholz	Farboption 077 (passend zu 076)
		basic material: surface:	chipboard (22) melamine	chipboard (22) real wood veneer	colour 077 (matches with 076)
<i>linke und rechte Ankettung möglich / left and right connection possible</i>			SM	SF	
<i>schwenkbar / swivelling</i>					
					
		IMC1AB2-01-ST- **			-FO5
					
		IMC1AB2-02-ST- **			-FO5
<i>Notwendige Farbangaben: Necessary colour details:</i>		1. Gestell / frame	3. Platte / top		2. Fußplatte foot plate
		2. Fußplatte / foot plate			

- **Ankettische nicht in Verbindung mit starren oder höheneinstellbaren Arbeitstischen!**
- **Add-on desks are not possible with fixed height desks or desks with initial height adjustment!**

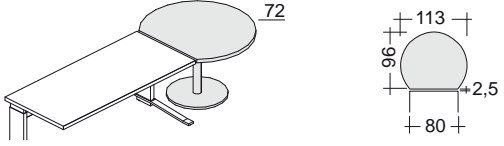
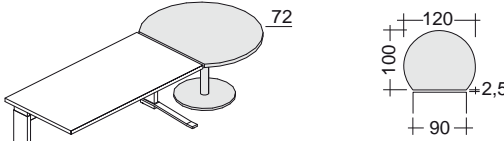
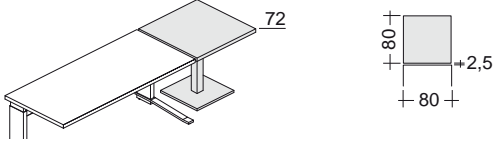
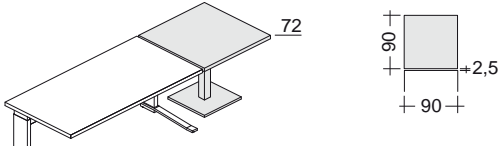
Ankettische Besprechung, Gruppe 3		add-on conference desks, group 3			
		Trägermaterial: Oberfläche:	Spanplatte (22) Melamin	Spanplatte (22) Echtholz	Farboption 077 (passend zu 076)
		basic material: surface:	chipboard (22) melamine	chipboard (22) real wood veneer	colour 077 (matches with 076)
linke und rechte Ankeftung möglich / left and right connection possible			SM	SF	
					
			IMC1AB3-01-ST- **		-FO5
					
			IMC1AB3-02-ST- **		-FO5
					
			IMC1AB3-03-ST- **		-FO5
					
			IMC1AB3-04-ST- **		-FO5
Notwendige Farbangaben: Necessary colour details:		1. Gestell / frame	3. Platte / top		2. Fußplatte foot plate
		2. Fußplatte / foot plate			

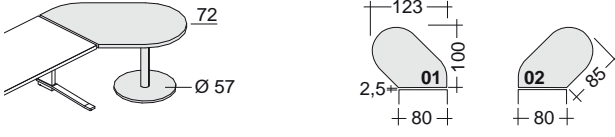
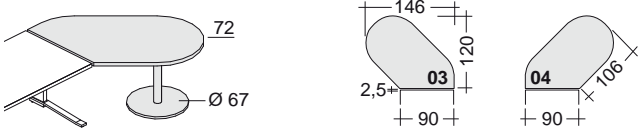
Ankettische Besprechung, Gruppe 4		add-on conference desks, group 4			
		Trägermaterial: Oberfläche:	Spanplatte (22) Melamin	Spanplatte (22) Echtholz	Farboption 077 (passend zu 076)
		basic material: surface:	chipboard (22) melamine	chipboard (22) r. wood veneer	colour 077 (matches with 076)
Plattenform / work top shape			SM	SF	
					
			IMC1AB4- **- ST- **		-FO5
					
			IMC1AB4- **- ST- **		-FO5
Notwendige Farbangaben: Necessary colour details:		1. Gestell / frame	3. Platte / top		2. Fußplatte foot plate
		2. Fußplatte / foot plate			

- Ankettische nicht in Verbindung mit starren oder höhenstellbaren Arbeitstischen!
- Add-on desks are not possible with fixed height desks or desks with initial height adjustment!

Besprechungstische quadratisch, freistehend, starr		square conference desks, fixed height, free standing			
		Trägermaterial: Oberfläche:	Spanplatte (22) Melamin	Spanplatte (22) Echtholz	Farboption 077 (passend zu 076)
		basic material: surface:	chipboard (22) melamine	chipboard (22) real wood veneer	colour 077 (matches with 076)
			SM	SF	
	72	IMCBTQ-08-ST-	**		-FO5
	72	IMCBTQ-09-ST-	**		-FO5
Notwendige Farbangaben: Necessary colour details:		1. Gestell / frame		3. Platte / top	
		2. Fußplatte / foot plate		2. Fußplatte foot plate	

Besprechungstische rund, freistehend, starr		round conference desks, fixed height, free standing			
		Trägermaterial: Oberfläche:	Spanplatte (22) Melamin	Spanplatte (22) Echtholz	Farboption 077 (passend zu 076)
		basic material: surface:	chipboard (22) melamine	chipboard (22) r. wood veneer	colour 077 (matches with 076)
			SM	SF	
	72	IMBR3-08-	**		-FO5
	72	IMBR3-10-	**		-FO5
	72	IMBR3-12-	**		-FO5
Notwendige Farbangaben: Necessary colour details:		1. Gestell / frame		3. Platte / top	
		2. Fußplatte / foot plate		2. Fußplatte foot plate	

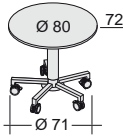
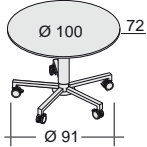
Besprechungstische rund, starr, fahrbar		round conference desks, fixed height, mobile			
		Trägermaterial: Oberfläche: basic material: surface:	Spanplatte Melamin chipboard melamine	Spanplatte Echtholz chipboard real wood veneer	
			SM	SF	
					
					IMBR1-08- **
					
					IMBR1-10- **
Notwendige Farbangaben: Necessary colour details:		1. Gestell / frame	2. Platte / top		

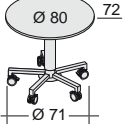
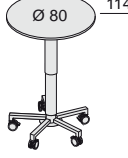
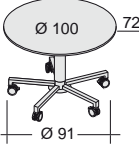
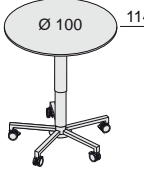
Besprechungstische rund, höhenverstellbar, fahrbar		round conference desks, height adjustable, mobile			
			SM	SF	
					
					IMBR2-08- **
					
					IMBR2-10- **
Notwendige Farbangaben: Necessary colour details:		1. Gestell / frame	2. Platte / top		

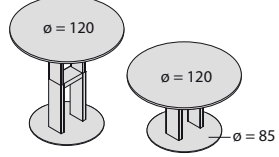
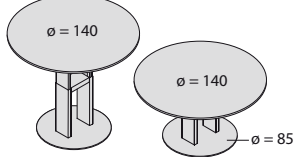
Besprechungstische rund, höhenverstellbar		round conference desks, height adjustable				
Verstellart / adjustment: H1: Hand / hand	Belastung / weight bearing: H1: 0 - 15 kg	Trägermaterial: Oberfläche: Ausgangshöhe ca: basic material: surface:	Spanplatte (22) Melamin 71 cm chipboard (22) melamine	Spanplatte (22) Echtholz 71 cm chipboard (22) r. wood veneer	Säulenprofile Alu gebürstet farblos eloxiert* columns* alu brushed clear anodised	Farboption 077 (passend zu 076) colour 077 (matches with 076)
			SM	SF		
						
						IMCBR4-12-H1- **
						
						IMCBR4-14-H1- **
Notwendige Farbangaben: Necessary colour details:		1. Gestell / frame	3. Platte / top		1. Gestell frame	2. Fußplatte foot plate
		2. Fußplatte / foot plate				

* Option -FO2: Säulenprofil Aluminium gebürstet farblos eloxiert 075, Gestell silber metallic 029

* option -FO2: columns aluminium brushed clear anodised 075, frame silver metallic 029

Verstellart / adjustment:

ST: starr / fixed height

H2: Hand mit Gewichtsausgleich / hand, with weight compensation

M1: Motor, Einfachsteuerung / motor, up and down

M2: Motor, Komfortsteuerung / motor, with memory function

Belastung / weight bearing:

H2: 0 - 40 kg

M1: 0 - 75 kg

M2: 0 - 75 kg

Besprechungstische rechteckig, höhenverstellbar rectangular conference desks, height adjustable

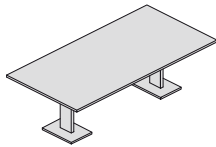

Trägermaterial: Oberfläche: Ausgangshöhe ca:	Spanplatte (22) Melamin 74 cm	Spanplatte (22) Echtholz 74 cm	Säulenprofile Alu gebürstet farblos eloxiert* 075	Farboption 077 (passend zu 076)
basic material: surface:	chipboard (22) melamine	chipboard (22) r. wood veneer	columns* alu brushed clear anodised 075	colour 077 (matches with 076)
	SM	SF		

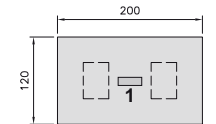

IMCBTR-20-ST- **			-FO2	-FO5
IMCBTR-20-H2- **			-FO2	-FO5
IMCBTR-20-M1- **			-FO2	-FO5
IMCBTR-20-M2- **			-FO2	-FO5

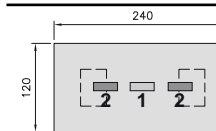

IMCBTR-24-ST- **			-FO2	-FO5
IMCBTR-24-H2- **			-FO2	-FO5
IMCBTR-24-M1- **			-FO2	-FO5
IMCBTR-24-M2- **			-FO2	-FO5

Besprechungstische Freiform, höhenverstellbar free form conference desks, height adjustable

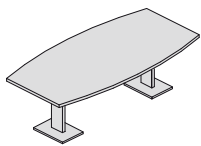

Trägermaterial: Oberfläche: Ausgangshöhe ca:	Spanplatte (22) Melamin 74 cm	Spanplatte (22) Echtholz 74 cm	Säulenprofile* Alu gebürstet farblos eloxiert 075	Farboption 077 (passend zu 076)
basic material: surface:	chipboard (22) melamine	chipboard (22) r. wood veneer	columns* alu brushed clear anodised 075	colour 077 (matches with 076)
	SM	SF		

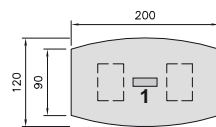

IMCBTF-20-ST- **			-FO2	-FO5
IMCBTF-20-H2- **			-FO2	-FO5
IMCBTF-20-M1- **			-FO2	-FO5
IMCBTF-20-M2- **			-FO2	-FO5

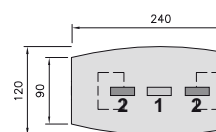

IMCBTF-24-ST- **			-FO2	-FO5
IMCBTF-24-H2- **			-FO2	-FO5
IMCBTF-24-M1- **			-FO2	-FO5
IMCBTF-24-M2- **			-FO2	-FO5

Notwendige Farbangaben: Necessary colour details:	1. Gestell / frame	3. Platte / top	1. Gestell frame	2. Fußplatte foot plate
	2. Fußplatte / foot plate			

Weitere Optionen further options

Option	Beschreibung	description	Preis / price
-TB1	Ausschnitt für Turnbox (1x), Position 1	cutout for turnbox (1x), position 1	
-TB2	Ausschnitt für Turnbox (2x), Position 2, nur für Tischbreite 240 cm	cutout for turnbox (2x), position 2, only for desk width 240 cm	
-KS1	Ausschnitt für Kabelschacht (1x), Position 1	cutout for cable duct (1x), position 1	
-KS2	Ausschnitt f. Kabelschacht (2x), Pos. 2, nur für Tischbreite 240 cm	cutout for cable duct (2x), pos. 2, only for desk width 240 cm	
-Z3	höheres Zusatzgewicht für H2 (20-60 kg)	higher additional weight for H2 (20-60 kg)	
-Z4	höheres Zusatzgewicht für H2 (40-80 kg)	higher additional weight for H2 (40-80 kg)	
-ZM	höheres Zusatzgewicht für M1 und M2 (40-115 kg)	higher additional weight for M1 and M2 (40-115 kg)	

- Kabelwanne Typ 3, für Kabelschacht, siehe 07.01
- Kabelschächte siehe separate Preisliste "Systemverkabelung"!
- Cable tray type 3, for cable duct see 07.01
- Cable duct see separate price list "Electrical Accessories"!

* Option -FO2: Säulenprofil Aluminium gebürstet farblos eloxiert 075, Gestell silber metallic 029

* option -FO2: columns aluminium brushed clear anodised 075, frame silver metallic 029

Kabelwanne, Typ 1 cable tray, type 1

Breite / width	
60 cm	IMKW1- 06
80 cm	IMKW1- 08

Notwendige Farbangaben / necessary colour details: Kabelwanne / cable tray

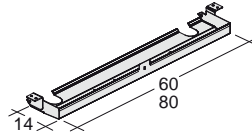
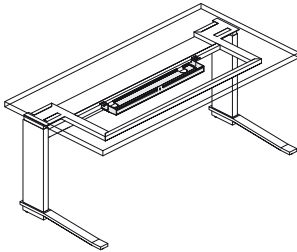

- abklappbar
 - 60 cm Breite für rechteckige und angewinkelte Arbeitstische, Schenkellänge 120 cm (Platten 03 - 10)
- sonst 80 cm Breite (auch f. Eckarbeitstische)
 - keine Kabelwanne für Schenkellänge 80 cm
 - Montage vor der Traverse
 - inkl. 2 Einfach-Kabelbügel
- swinging downwards for easy access
 - 60 cm wide cable trays for rectangular and angled work stations with side length 120 cm (tops 03-10)
- for all other tops 80 cm width (also for corner work stations)
 - no cable tray for 80 cm side length possible
 - positioned in front of the cross rail
 - with 2 cable bows

Kabelwanne, Typ 2 cable tray, type 2

für Tischbreite for desk width	Variante variant
	2 / 3
180 / 183 cm	IMKW2- 18- *
200 / 203 cm	IMKW2- 20- *
223 cm	IMKW2- 22- *

Notwendige Farbangaben / necessary colour details: Kabelwanne / cable tray

Varianten
-2: für Korpusunterbau links (183, 203, 223 cm breit)
-3: für Korpusunterbau rechts (183, 203, 223 cm breit)
Variants
-2: for pedestals or sideboards left side (183, 203, 223 cm wide)
-3: for pedestals or sideboards right side (183, 203, 223 cm wide)

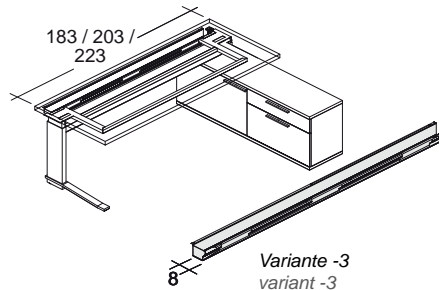
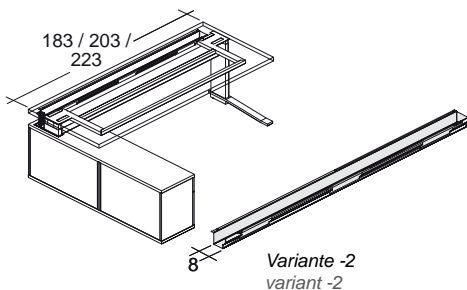

- deckt die komplette Tischbreite ab
 - Montage hinter der Traverse
 - inkl. 2 Einfach-Kabelbügel
 - keine Steckerleistenbefestigung möglich
 - nicht für freistehende Arbeitstische
- for entire width of desk
 - positioned behind the cross rail
 - incl. 2 cable bows
 - plug panel fixing not possible
 - not in combination with free-standing work stations

Kabelwanne, Typ 3 cable tray, type 3

für Tischbreite / desk width	
200 cm	IMKW3- 20
240 cm	IMKW3- 24

Notwendige Farbangaben / necessary colour details: Kabelwanne / cable tray

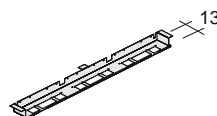
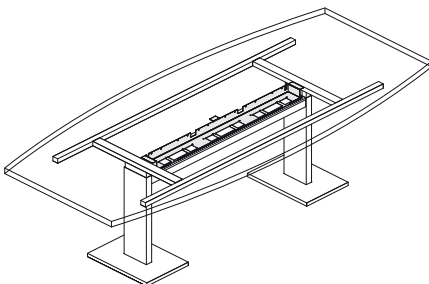

- nur für höhenverstellbare Besprechungstische
 - in Verbindung mit Kabelschacht
 - Montage über der Traverse
- only for height adjustable conference desks
 - in combination with cable duct
 - positioned above the cross rail

Weiteres Zubehör siehe separate Preisliste "Systemverkabelung"!
Further accessories see separate price list "Electrical Accessories"!

Kabelwanne, Typ 4		cable tray, type 4	
Breite / width			
100 cm	IMCKW4- 10		125,--
120 cm	IMCKW4- 12		131,--
140 cm	IMCKW4- 14		136,--
160 cm	IMCKW4- 16		142,--
180 cm	IMCKW4- 18		151,--
200 cm	IMCKW4- 20		158,--
Notwendige Farbangaben / necessary colour details:		Kabelwanne / cable tray	

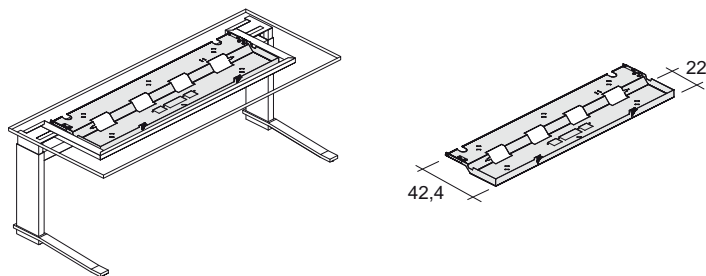

- abklappbar
- nicht in Verbindung mit Arbeitstischen für Korpusunterbau
- nicht in Verbindung mit starren oder höheneinstellbaren Arbeitstischen!
- bitte unbedingt die Draufsichten der Tische beachten, wo die maximale mögliche Breite der Kabelwannen angegeben ist
- swinging downwards for easy access
- not possible with work stations for pedestal or lowboard
- not possible with fixed height desks or desks with initial height adjustment!
- please pay attention to the top view of the desks, where the maximum possible width of the cable tray is indicated

Kabelkette		cable chain	
mit Standfuß - vom Boden bis zur Platte / with foot - from floor to work top		IMKK1	106,--
Notwendige Farbangaben / necessary colour details:		1. Kabelkette / cable chain 2. Standfuß / foot	

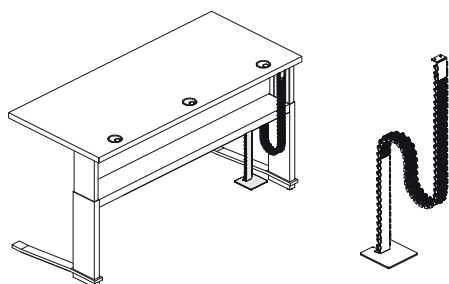

- inkl. 2 Einfach-Kabelbügel
- with 2 cable bows

Kabelschlange		cable chain	
<ul style="list-style-type: none"> • für starre und höheneinstellbare Tische • Montage an der Traverse • for work stations, fixed height and height adjustable • fixed to the cross rail 		IMKKS	36,--
Notwendige Farbangaben / Necessary colour details:		Kabelschlange / cable chain	

Kabelsets		cabling sets	
Verkabelungsset 1 (bestehend aus Kabelwanne Typ 1, 80 cm breit, Kabelkette mit Standfuß, Steckerleiste mit Netzanschlusskabel 3 m (in schwarz) und Befestigung in der Kabelwanne) cabling set 1 (consisting of cable tray type 1, 80 cm wide, cable chain with foot, plug panel with mains connection cable 3 m long (in black), fixed in the cable tray)		IMCVKSE-01	250,--
Verkabelungsset 2 (bestehend aus Kabelwanne Typ 1, 60 cm breit, Kabelkette mit Standfuß, Steckerleiste mit Netzanschlusskabel 3 m (in schwarz) und Befestigung in der Kabelwanne) cabling set 2 (consisting of cable tray type 1, 60 cm wide, cable chain with foot, plug panel with mains connection cable 3 m long (in black), fixed in the cable tray)		IMCVKSE-02	248,--
Notwendige Farbangaben / Necessary colour details:		1. Kabelwanne / cable chain 2. Kabelkette / cable chain 3. Standfuß / foot	

Weiteres Zubehör siehe separate Preisliste "Systemverkabelung"
Further accessories see separate price list "Electrical Accessories"!

Monitorarme

monitor arms

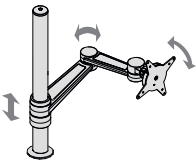

in der Tiefe dynamisch verstellbar, Bildschirm max. 8 kg, inkl. Schnellverschluss
dynamic adjustable in depth, monitor max. 8 kg, incl. quick release

IMZMA1

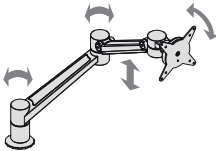

komplett dynamisch verstellbar, Bildschirm max. 7 kg, inkl. Schnellverschluss
completeley dynamic adjustable, monitor max. 7 kg, incl. quick release

IMZMA2

- für eine Organisationsbohrung
- nach VESA-Standard gefertigt (75 bzw. 100 mm Interface)
- for one organisation hole
- according to VESA standard (75 or 100 mm interface)

CPU-Halter

CPU stand

IMCZC1

Notwendige Farbangaben / Necessary colour details:

CPU-Halter / CPU stand

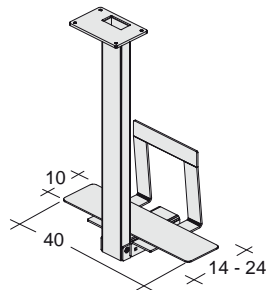
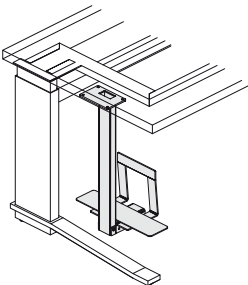

- Befestigung unterhalb der Tischplatte
- max. Nutzhöhe 52 cm
- max. Belastbarkeit 25 kg
- inkl. 2 Einfach-Kabelbügel

- fixed underneath the work top
- max. height of the CPU 52 cm
- max. load bearing capacity 25 kg
- with 2 cable bows

Rückwände

modesty panels

für Tischbreite / for desk width

120 cm

IMCZR1- 12

140 cm

IMCZR1- 14

160 cm

IMCZR1- 16

180 cm

IMCZR1- 18

200 cm

IMCZR1- 20

Notwendige Farbangaben für Befestigungsmaterial:

Necessary colour details for fixing material:

Metallteile / metal parts

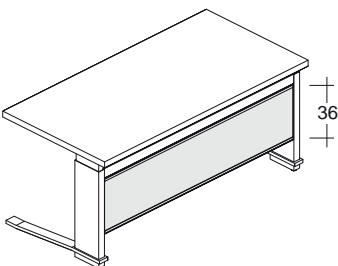

Aufsatzwand, 4 cm stark		table top screen, 4 cm thick	
		Stoffgruppe: fabric:	
	für Tischbreite / for desk width		
	120 cm	IMCAW- 12- 01	
	140 cm	IMCAW- 14- 01	
	160 cm	IMCAW- 16- 01	
	180 cm	IMCAW- 18- 01	
	200 cm	IMCAW- 20- 01	
Notwendige Farbangaben: Necessary colour details:		Stoff / fabric	

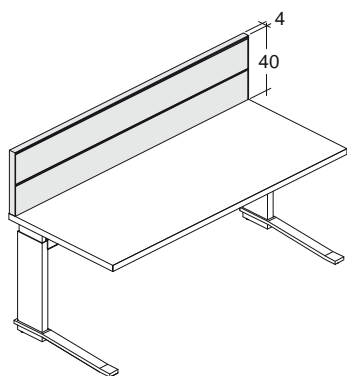



Aufsatzelemente mit hervorragenden akustischen Eigenschaften:

- Aluminiumrahmenprofil
- Füllstoff Brandklasse B1
- 100% recycelbar
- beidseitig organisierbar durch zwei waagrechte Systemschienen zum Einhängen von Zubehör
- Befestigung in zwei Organisationsbohrungen
- nicht in Verbindung mit Kabelschacht

Table top screen with excellent acoustic properties:

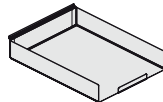
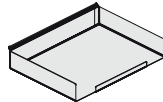
- aluminium frame
- filling material fire class B1
- 100% recyclable
- with two organisation rails on both sides for accessories
- fixing in two organisation holes
- not in combination with cable duct possible

Zubehör für die Aufsatzwand		accessories for the table top screen	
	Briefablage DIN A4 längs letter storage DIN A4, lengthwise	IMAWZBL	
	Briefablage DIN A4 quer letter storage DIN A4, crosswise	IMAWZBQ	
	Utensilien-Ablage utensil storage	IMAWZUT	
	Stiftköcher pencil box	IMAWZSK	

Schiebetür-Anstellelemente side cupboard units with sliding door

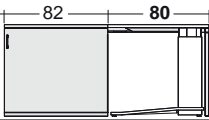
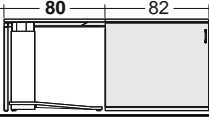
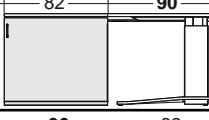
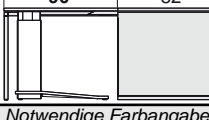
inkl. Griff -GN inkl. Holz-Einlegeboden incl. handle -GN incl. wooden shelf		Oberfläche Abdeckplatte/Front: surface of the top/front:	Melamin melamine	Echtholz real wood veneer	Griffe handles	Griffe handles	verschießbar lockable
für Tischtiefe / for desk depth			SM	SF			
	links / left	80 cm	IMAEL-08-*		-GA -GB -GG -GI	-GJ -GK -GM	-VS
	rechts / right	80 cm	IMAER-08-*		-GA -GB -GG -GI	-GJ -GK -GM	-VS
	links / left	90 cm	IMAEL-09-*		-GA -GB -GG -GI	-GJ -GK -GM	-VS
	rechts / right	90 cm	IMAER-09-*		-GA -GB -GG -GI	-GJ -GK -GM	-VS
Notwendige Farbangaben: Necessary colour details:		1. Korpus / carcass	2. Abdeckplatte und Front / top and front				

Traversenrohre cross bars

Gestell für Einzeltische, 80 cm tief, links angestellt / frame for single desks, 80 cm deep, left position	IMATL-08
Gestell für Einzeltische, 80 cm tief, rechts angestellt / frame for single desks, 80 cm deep, right position	IMATR-08
Gestell für Einzeltische, 90 cm tief, links angestellt / frame for single desks, 90 cm deep, left position	IMATL-09
Gestell für Einzeltische, 90 cm tief, rechts angestellt / frame for single desks, 90 cm deep, right position	IMATR-09
Verbindungsrohre für Doppelarbeitsplatz, jeweils 80 cm tief / connection bars for double desks, 80 cm deep each	IMATD-08
Verbindungsrohre für Doppelarbeitsplatz, jeweils 90 cm tief / connection bars for double desks, 90 cm deep each	IMATD-09
Notwendige Farbangaben: / Necessary colour details:	Gestell / frame

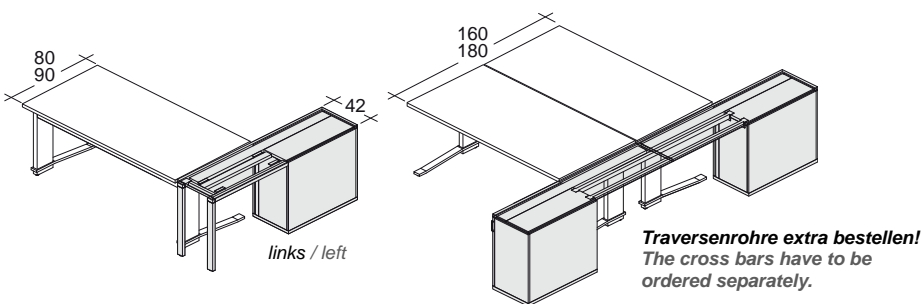

- Schiebetür-Anstellelement unabhängig vom Arbeitstisch
- Elemente mit Hängerahmen bieten keinen zusätzlichen Stauraum für Ordner
- the side cupboard unit with sliding door is not fixed at the work desk
- units with a A4 filing frame do not offer additional storage for ring binders

Inneneinteilungen - auch zur nachträglichen Montage interior accessories - also for later assembly

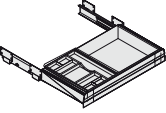
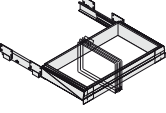
	Breitschub mit Materialschale organisation drawer with pencil tray	IMAE-BS3	
	pro Element ist nur 1 Hängerahmen möglich! only 1 filing frame possible for each unit!	Auszug für A4-Hängemappen A4 filing frame	IMAE-HR3
	Holz-Einlegeboden / wooden shelf	IMAE-080/04-ZHEB	
Notwendige Farbangaben: / Necessary colour details:		Korpus / carcass	

